

**Operating manual
Diesel engine
D 846**

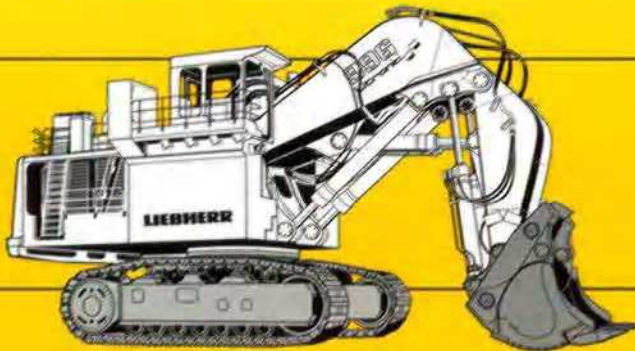
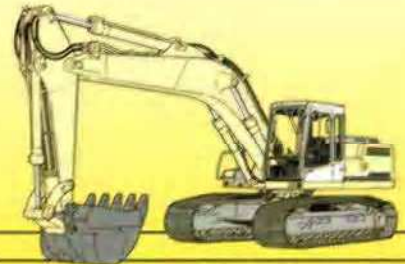

en

Operating manual

Diesel engine

D 846

Document identification

Order number: 9739303

Version: 06.06.2005

Document version:
01

Author: LMB/Abteilung-BE-MD3

Product identification

Type: D 846

Serial number: 2005020000

Address

Address: LIEBHERR MACHINES BULLE S.A.
45, rue de l'Industrie
CH-1630 BULLE
SWITZERLAND

Manufacturer

Name: LIEBHERR MACHINES BULLE S.A

Machine data:

Complete the following details upon delivery of your diesel engine.

*These details are indicated on the identification plate of the diesel engine. This will also prove beneficial when ordering spare-parts.

*** Diesel engine ident. no.:**

.

*** Diesel engine serial no.:**

. . . .

Date of initial start-up:

. . / . . / . .

This operating manual has been compiled for the **operator** and for the **maintenance personnel** of the diesel engine.

The manual includes descriptions regarding:

- Technical data
- Safety requirements
- Operation and servicing
- Maintenance

The operating manual is to be read thoroughly and referred to before initial start-up and at regular periods thereafter by each person contracted to carry out work with/on the diesel engine.

Tasks with, or on, the diesel engine for example include:

- **Operation**, servicing, disposing of fuels and lubricants.
- **Repair**, including maintenance and inspection.

This simplifies training of the operator for his diesel engine and prevents malfunctions resulted from improper use.

Please understand that we do not recognise warranty claims submitted as a result of improper operation, insufficient maintenance, the utilisation of impermissible fuels or negligence of the safety guidelines.

LIEBHERR will revoke any obligations submitted to **LIEBHERR** and/or their dealers, such as guarantees, service orders, etc. without notice, if any parts other than original **LIEBHERR** parts or spare-parts sold by **LIEBHERR** are used for maintenance and repair.

It may be necessary to undertake maintenance tasks more regularly than is prescribed in the inspection plan when working in tougher conditions.

Modifications, conditions and copyright:

- Modifications of technical details, as regards information and illustrations within the documentation currently valid for the machine remain reserved.

Conditions for warranty and liability of the general terms of trade for the **LIEBHERR** Company are not extended by the aforementioned details.

Information and diagrams featured within this operating manual may not be reproduced and distributed, nor used for the purpose of the competition. All rights remain exclusively reserved in accordance with copyright laws.

1	Product description	1 - 1
1.1	Technical data	1 - 5
1.1.1	Diesel engine	1 - 5
1.1.2	Cylinder head	1 - 5
1.1.3	Coolant pump	1 - 5
1.1.4	Coolant thermostat	1 - 6
1.1.5	Alternator	1 - 6
1.1.6	Starter	1 - 6
1.1.7	Flywheel housing	1 - 6
1.1.8	Air compressor	1 - 6
1.1.9	Explanation of type description	1 - 7
1.1.10	Design features	1 - 8
1.1.11	Special equipment	1 - 10
2	Safety regulations	2 - 1
2.1	Introduction	2 - 1
2.2	General safety guidelines	2 - 1
2.3	Use as directed	2 - 2
2.4	Notes on the prevention of crushing and burns	2 - 2
2.5	Notes on the prevention of fire and explosions	2 - 3
2.6	Observe safety precautions when starting	2 - 3
2.7	Measures for safe maintenance	2 - 3
2.8	Observe the safety precautions for diesel engines featuring electronic control units	2 - 5
2.9	Safety and emergency run program for diesel engines featuring electronic control units	2 - 5
2.10	Disposing of fuels and lubricants	2 - 6
3	Operation, Handling	3 - 1
3.1	Control elements and operating elements	3 - 1
3.2	Operation	3 - 2
3.2.1	Preparing for initial start-up	3 - 2

3.2.2	Maintenance tasks before daily start-up	3 - 3
3.2.3	Starting the diesel engine	3 - 3
3.2.4	Precautions for starting up in icy temperatures	3 - 4
3.2.5	Shutting down	3 - 5
4	<u>Malfunctions</u>	4 - 1
4.1	Error code tables	4 - 1
5	<u>Maintenance</u>	5 - 1
5.1	Maintenance and inspection schedule	5 - 1
5.2	Lubricant chart, Filling quantities	5 - 4
5.2.1	Table of filling quantities	5 - 4
5.2.2	Lubricant chart	5 - 4
5.3	Maintenance tasks	5 - 6
5.3.1	Special tools for maintenance tasks	5 - 6
5.3.2	Preparatory tasks for maintenance	5 - 7
5.3.3	Maintenance tasks (daily) every 10 operating hours	5 - 7
5.3.4	Maintenance tasks (daily) every 50 operating hours	5 - 11
5.3.5	Maintenance tasks every 400 operating hours	5 - 12
5.3.6	Diesel engine	5 - 12
5.3.7	Cylinder head	5 - 18
5.3.8	Cooling system	5 - 23
5.3.9	Oil system and fuel system	5 - 24
5.3.10	Maintenance tasks every 800 operating hours	5 - 24
5.3.11	Diesel engine	5 - 25
5.3.12	Flame-type kit	5 - 25
5.3.13	Fuel pre-filter	5 - 28
5.3.14	Fuel fine filter	5 - 29
5.3.15	Bleed the fuel system	5 - 31
5.3.16	Maintenance tasks every 3200 operating hours	5 - 32
5.3.17	Cooling system	5 - 32

5.3.18	Maintenance tasks as required	5 - 33
5.3.19	Diesel engine	5 - 33
5.3.20	Dry-air filter	5 - 34
5.3.21	Cooling system	5 - 34
5.3.22	Transport	5 - 36
5.3.23	Storage	5 - 37
5.3.24	Confirmation of maintenance tasks which have been carried out	5 - 38
5.3.25	every 400 operating hours / at least once a year	5 - 38
5.3.26	Additionally, every 800 / 1600 / 2400 / 3200 operating hours	5 - 39
5.3.27	Additionally every 2 years	5 - 40
5.4	Lubricants and fuels	5 - 41
5.4.1	Handling lubricants and fuels	5 - 41
5.4.2	Environmental-protection measures	5 - 41
5.4.3	Disposing of recyclables	5 - 41
5.4.4	Lubricant and fuel specifications	5 - 41
5.4.5	Diesel fuels	5 - 42
5.4.6	Coolant for diesel engines	5 - 42
5.4.7	Lube-oils for the diesel engine	5 - 48

1 Product description

Equipment layout

This section features a summary of the diesel engine including a description of the components represented.

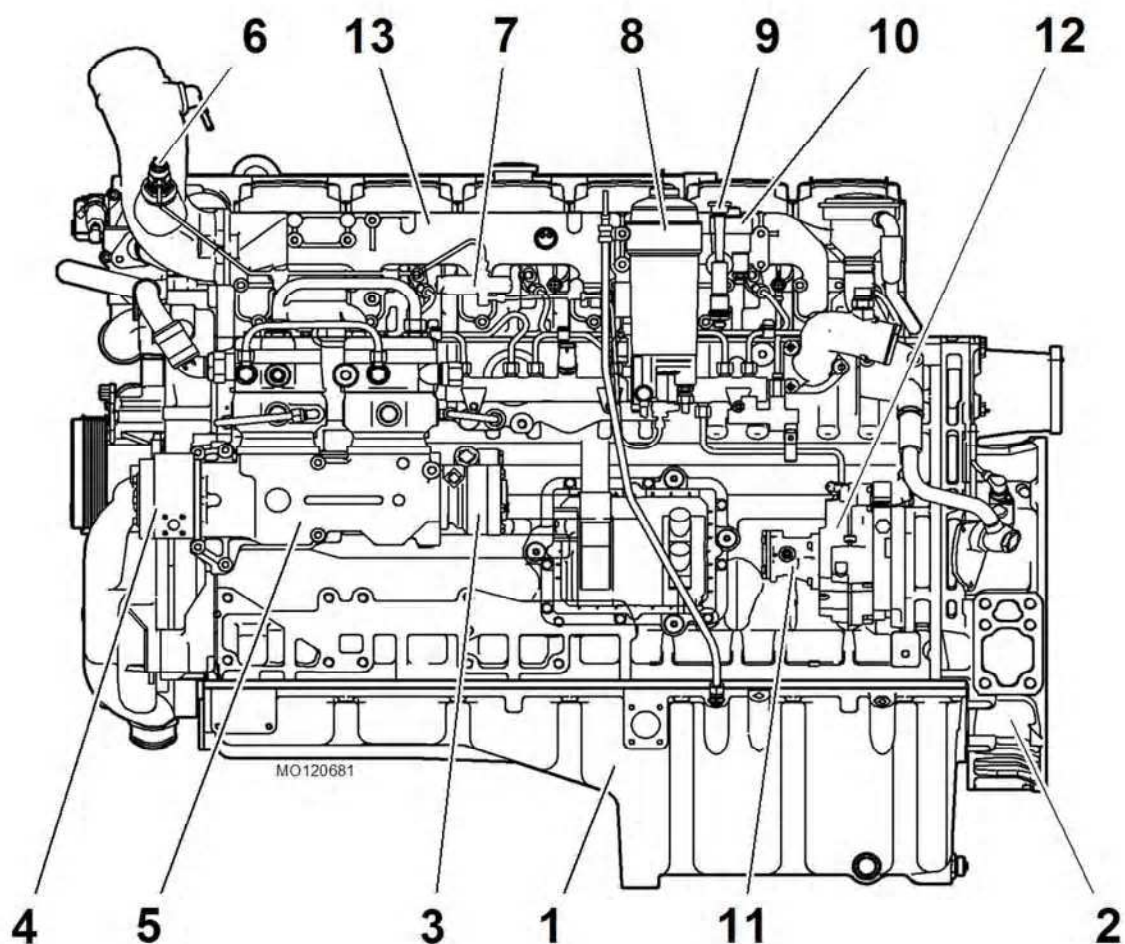

Components of the diesel engine / as viewed from the left-hand side

- | | | |
|--------------------|--|----------------------------|
| 1 Oil sump | 6 Flame glow plug | 10 Fuel pre-filter |
| 2 Flywheel housing | 7 Solenoid valve / Flame-type start system | 11 Fuel transfer pump |
| 3 Hydraulic pump | 8 Fuel fine filter | 12 Fuel high-pressure pump |
| 4 Hydraulic pump | 9 Fuel manual delivery pump | 13 Air induction pipe |
| 5 Air compressor | | |

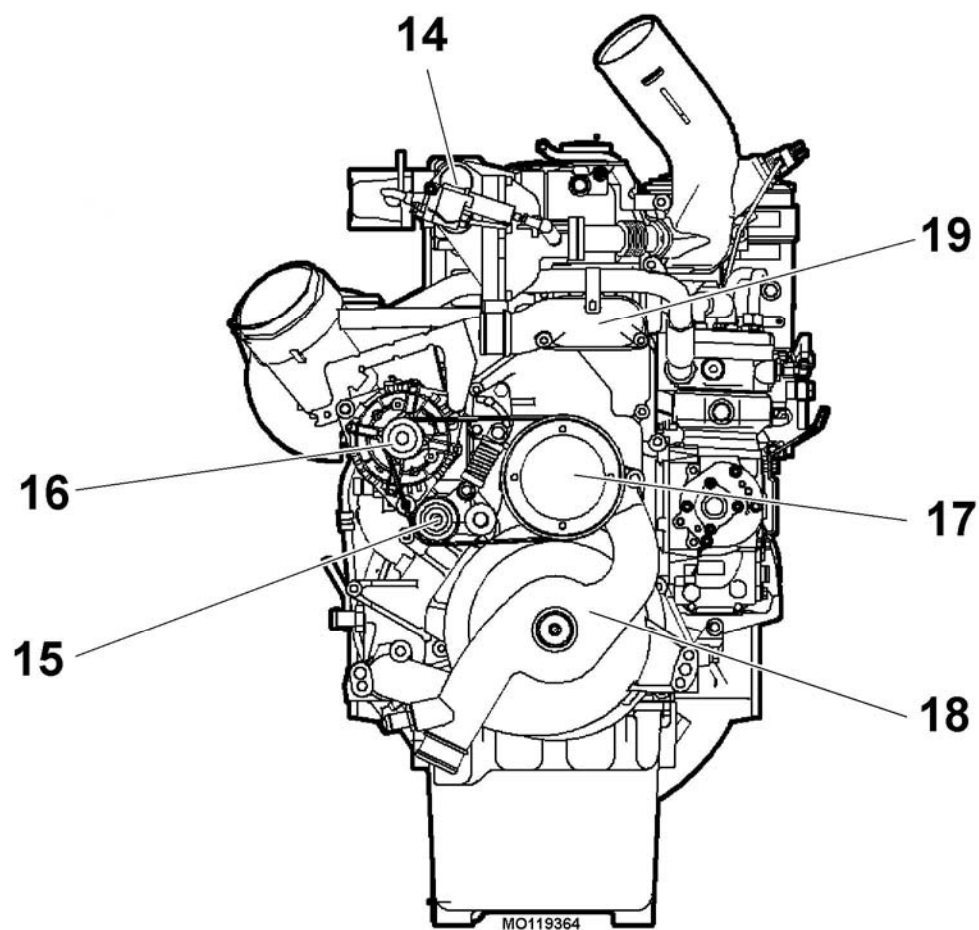

Components of the diesel engine / as viewed from the opposite side of the flywheel

14 Exhaust gas recirculation (AGR)

15 Ribbed V-belt tensioning device
16 Alternator

17 Fan drive
18 Coolant pump
19 Thermostat housing

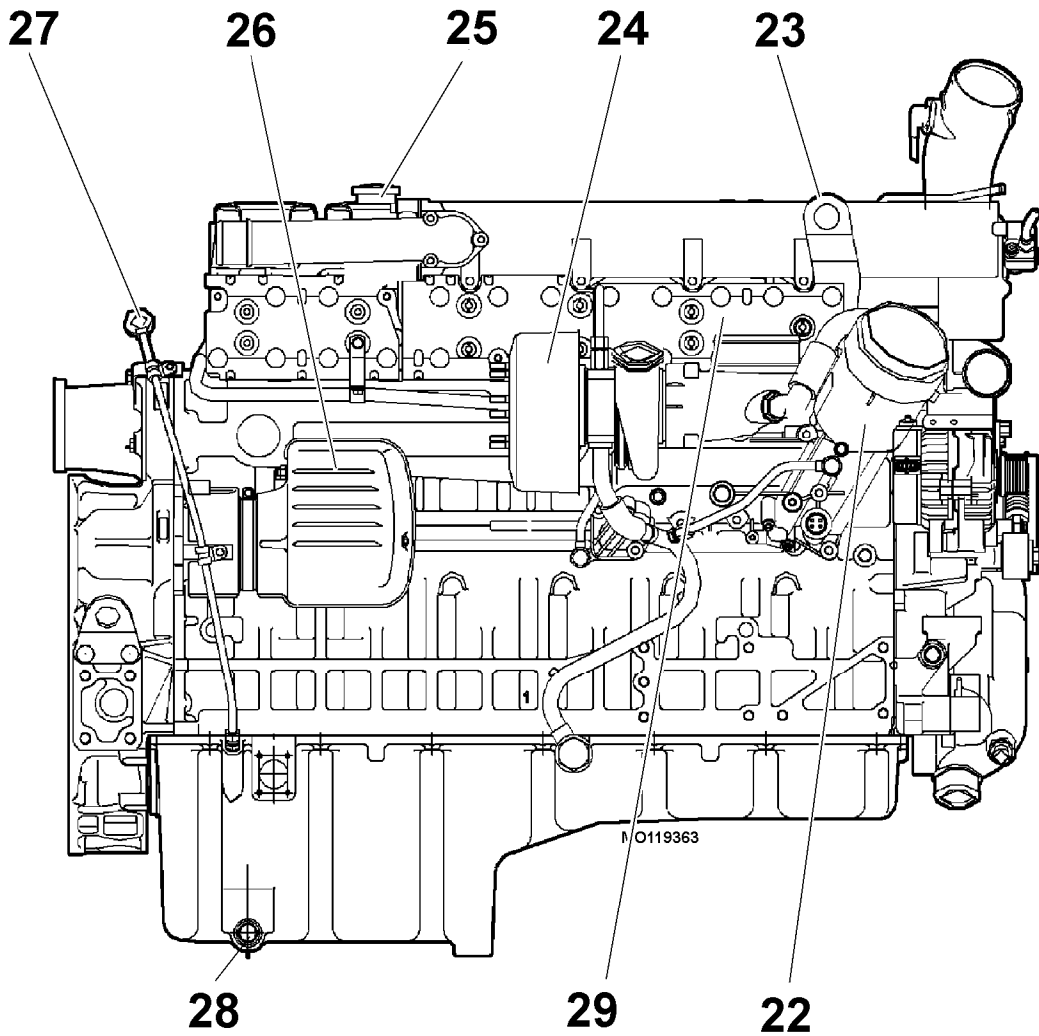

Components of the diesel engine / as viewed from the right-hand side

- | | | |
|-------------------------|----------------------|---------------------|
| 22 Oil filter | 25 Oil filler nozzle | 28 Oil drain valve |
| 23 Lifting lug | 26 Starter | 29 Exhaust gas pipe |
| 24 Exhaust turbocharger | 27 Oil dipstick | |

LMB/01/003801/6.5/en/Version: 06.06.2005

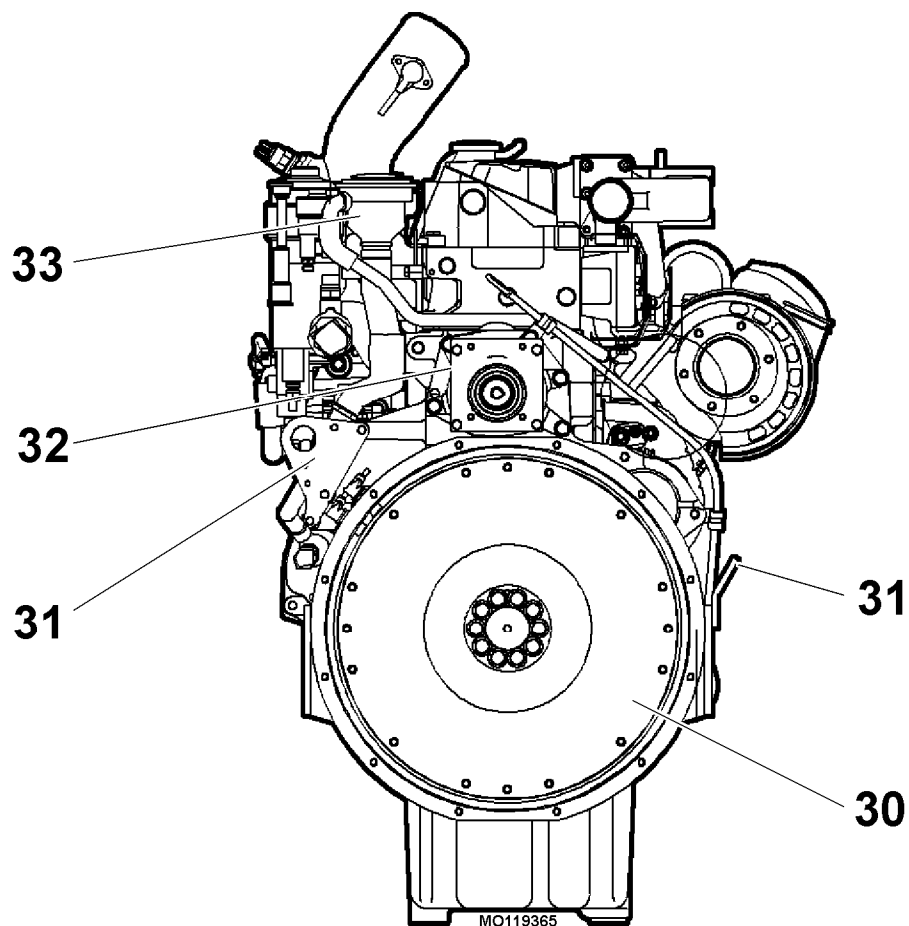

Components of the diesel engine / as viewed from the side of the flywheel

30 Flywheel
31 Lifting lug

32 Power take-off
33 Oil separator

1.1 Technical data

1.1.1 Diesel engine

Name	Value	Units
Design	In-line diesel engine	
Number of cylinders	6	
Firing sequence	1-5-3-6-2-4	
Bore	128	mm
Stroke	166	mm
Displacement	12.82	Litres
Compression ratio	18:1	
Diesel engine's direction of rotation (looking at the flywheel)	left	
Performance group	LG1	
Power rating in accordance with	ECE R24	
Nominal output	350/370	kW
Speed rating	1900	min ⁻¹
Emission standards	2001/63/EC-stage 3 / EPA/CARB-Tier III	
D846 diesel engine weight (without water, without oil)	approx. 1085	kg

1.1.2 Cylinder head

Name	Value	Units
Valve clearance intake cold	0.50	mm
Valve clearance exhaust valve fitting/rocker arm cold	0.80	mm
Valve clearance exhaust valve fitting/retainer cold	0.60	mm

1.1.3 Coolant pump

Name	Value	Units
Flow rate (at nominal speed 1900 min ⁻¹ and counter-pressure 0.6 bar)	530	l/min

1.1.4 Coolant thermostat

Name	Value	Units
Beginning of opening	79	°C
Fully opened	94	°C

1.1.5 Alternator

Name	Value	Units
Voltage	28	V
Amperage	110	A

1.1.6 Starter

Name	Value	Units
Voltage	24	V
Output	6,6	kW

1.1.7 Flywheel housing

Name	Value	Units
Connection	SAE 1	

1.1.8 Air compressor

Name	Value	Units
Flow rate at nominal speed 1900 min ⁻¹ and 10.5 bar	550	l/min
Gear transmission ratio	1:1,15	
Water-cooled	Yes	

1.1.9 Explanation of type description

Type description

			Description
D	84	6	Type description
D			Diesel engine turbocharged with intercooling
	84		Bore 128 mm, Stroke 166 mm
		6	Number of cylinders (6 cylinder)

Diesel engine type identification plate

A diesel engine identification plate has been mounted on the right-hand side of the crankcase looking at the flywheel, or on the air induction pipe.

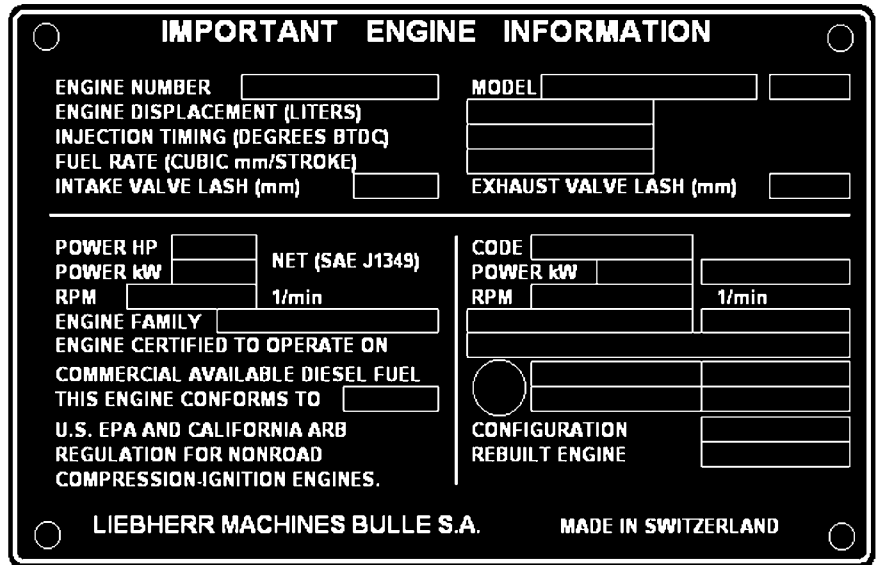

Identification plate

Diesel engine number

The EN code is stamped onto the diesel engine identification plate and in the crankcase. On the crankcase, the EN code is at the end of the top surface of cylinder 4 or 6 depending on the number of cylinders of the diesel engine.

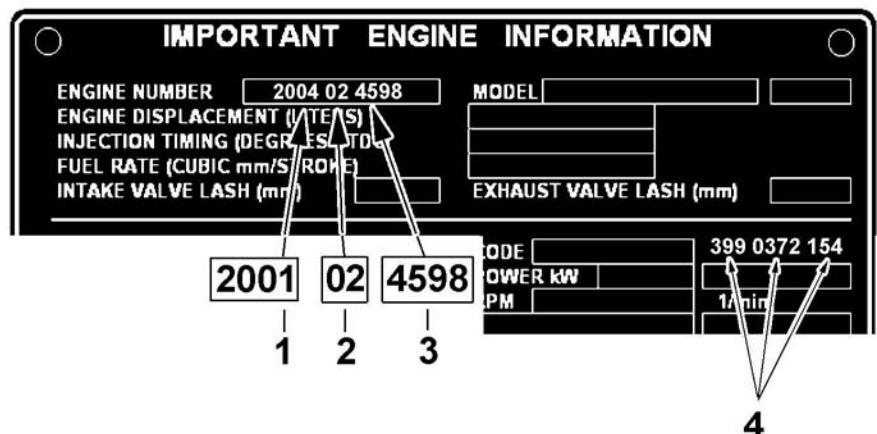

Diesel engine number

- 1 Year (4-digit)
- 2 Number of cylinders (02=6 cylinders)
- 3 Serial number
- 4 EN-code

LMB/01/003801/6.5/en/Version::06.06.2005

Cylinder description, rotational direction

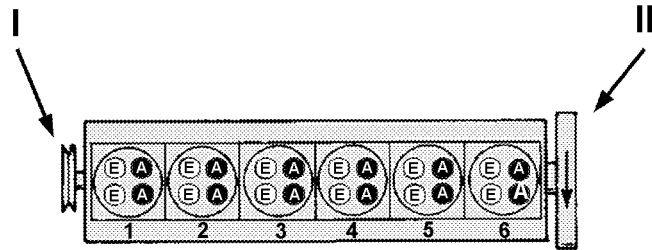

Cylinder description — Rotational direction

- I The opposite side of the flywheel
- II Flywheel side
- A Exhaust valve
- E Intake valve

Cylinder 1 is located on the opposite side of the flywheel.

1.1.10 Design features

- Design** Water-cooled 6-cylinder in-line diesel engine with direct injection, exhaust turbocharging and air/air-intercooling.
- Features** A rugged basic design and largely-dimensioned size form the basis for optimum operating safety and long life-expectancy. Reduced fuel-consumption, as well as low noise and exhaust emissions due to a combustion process which is specially adapted to suit the requirements. Reduced maintenance to easily accessible components and a multitude of mounting options for special equipment contribute to optimum overall efficiency of the diesel engines.
- Engine** The 6-cylinder diesel engines feature a steel crankshaft with 7 bearing points all radii-hardened, with inductive hardened running surfaces and 8 forged-on counterweights.
A torsion damper has been fitted on the hub for the water pump drive. Forge pressed, diagonally-sectioned connecting rod, transmission bearing in lead bronze-triplex-friction bearings or Sputter bearing. Smooth-rod three ring piston made of aluminium alloy featuring ring inserts and combustion recess in the piston crown. Replaceable, wet cylinder liners
- Housing** Crankcase designed as one unit made of alloyed cast iron. 4-valve individual cylinder head with cast integral swirl inlet duct, as well as replaceable valve seat rings and valve guides.
Flywheel housing, front-mounted aggregate carrier and oil sump mounted on the underside encase the diesel engine.
- Drive control** Two intake valves and exhaust valves respectively per cylinder suspended in the cylinder head (ohv.). Actuated by steel-camshaft featuring 7 bearings via tappet, push rod and rocker arm. Drive of the cam shaft, high-pressure pump, lube-oil pump, air compressor, water pump and auxiliary hydraulic pumps from the crankshaft via gears on the front and rear side of the engine.

LMB/01/003801/6.5/en/Version:::06.06.2005

Lubrication	Forced-feed lubrication with gear pump for crankshaft bearing, connecting rod bearing and camshaft bearing, as well as small end bush, tappet and rocker arm. Oil filtering via a Mono-oil filter mounted in an inclined position directly on the crankcase pointing forward with replaceable paper cartridges. Accessories such as high-pressure pump and air compressor are connected to the diesel engine lube-oil circuit. The diesel engine oil cooler is integrated in the cooling water circuit.
Cooling	Double-thermostatic regulated liquid cooling with coolant pump. Individual supply of each cylinder unit via cast distributor ducts in the crankcase. Piston cooling via oil spraying in the cooling channel from the lube-oil circuit of the diesel engine.
Injection system	High-pressure pump with flow control, supplied from a flange-mounted fuel transfer pump. Fuel filter; Rail; CR injectors with 7-jet blind hole nozzles.
Flame-type start system	The flame-type start system is a cold-start aid for low ambient temperatures. The flame glow plug, installed in the air induction pipe, is supplied with fuel via a solenoid valve with batching nozzle and can be ignited.
Electrical equipment	Starter and alternator: 24 Volt.
Electronic sensors on the engine side	Charge air pressure sensor, temperature sensor for refrigerant and charge air, speed sensors and oil pressure sensor are interfaces for external monitoring and control functions. The individual functions and error reports are described in the respective user documentation.
Diesel engine brake	The diesel engine exhaust gas brake flap is installed in the exhaust gas pipe which runs from the exhaust turbocharger to the muffler. The diesel engine exhaust gas brake flap is actuated via a cylinder pressurised with compressed air, whereby the diesel engine braking action is generated via closing of the diesel engine exhaust gas brake flap.
Diesel engine brake and auxiliary brake system	A diesel engine auxiliary brake system (ZBS), in addition to the diesel engine exhaust gas brake flap, has been installed to increase diesel engine braking action. Thus, during the engine braking procedure, the ZBS allows a gap in the exhaust valves to remain open, increasing diesel engine braking action.
Exhaust gas recirculation (AGR)	With the AGR, part of the combusted, hot exhaust gases are channelled back to the cylinder charge via a heat exchanger integrated in the engine cooling system. Lower combustion temperatures are resulted and thus lower NO _x —emissions.
Fan clutch	The fan is powered via a viscous fan clutch.
Electronic diesel engine regulation	The electronic diesel engine governor (EDC) serves to regulate the speed, injection begin and torque of LIEBHERR diesel engines. The EDC is comprised essentially of sensors and the control unit. Devices located on the same side as the diesel engine and on the same side as the vehicle are connected to the EDC-control unit via cable harnesses.
Air compressor	The air compressor is flanged on one of the auxiliary drives integrated on the diesel engine. Cooling or lubrication of the air compressor is connected to the respective circuits of the diesel engine.
Mounting possibilities for hydraulic gear-type pumps	The mounting of hydraulic gear pumps is possible on the camshaft auxiliary drive, as well as on the air compressor and on the auxiliary drive on the flywheel side.

1.1.11 Special equipment

Air-conditioning compressor

The air-conditioning compressor can be mounted directly onto the diesel engine and powered via a magnetic clutch featuring a ribbed V-belt. When the air-conditioning is switched on, the magnetic clutch is active and the compressor is working.

Preheating of the cooling water

Cooling water preheating unit from the Calix Company (220V, 1100W)

2 Safety regulations

Working on the diesel engine is extremely hazardous to user, machine operator or maintenance technician. Dangers and accidents can be avoided if the various notes on safety are frequently read and adhered to. This applies in particular for personnel carrying out maintenance tasks opportunely on the diesel engine.

Conscientious adherence of the safety guidelines specified as follows, will guarantee the safety of yourself and others, as well as safeguarding against damage to the diesel engine.

All necessary safety precautions relevant to the description of tasks which could cause injury to personnel or damage to the diesel engine, are described in this book.

They are indicated with the references **Danger**, **Warning** or **Caution**.

2.1 Introduction

1. The terms represent the following meaning throughout this book:



Danger

warns against certain operational procedures which could lead to fatalities should the respective precautionary measures not be observed.



Warning

warns against certain operational procedures which could lead to serious physical injury should the respective precautionary measures not be observed.



“**Caution**” warns against certain operational procedures which could lead to minor physical injury, or damage to the diesel engine, should the respective precautionary measures not be observed.



“Note”

Provides additional information to certain operational procedures.

2. **Observation of these points does not exempt you from the adherence of additional rules and regulations!**

All safety regulations valid for the application site are also to be adhered to.

2.2 General safety guidelines

1. Familiarise yourself with the operating and maintenance instructions before starting up the engine.
Make sure that you possess, have read, and have understood any additional instructions relevant to the engine's optional features.
2. Only expressly authorised personnel may operate, maintain or repair the diesel engine.
Observe the legal, permissible minimum age!
3. Employ only trained or instructed personnel and allocate definitive responsibility for personnel regarding operation, setting up, maintenance and repair.
4. Personnel who are still undergoing training, or are involved with a general apprenticeship, should only be allowed to work on the diesel engine while under constant supervision of an experienced person.

5. Ensure regularly that personnel are conscientious of the safety and dangers while working and are observing the operating instructions.
6. Always wear safety clothing when working on the diesel engine. Avoid the wearing of rings, wrist watches, ties, scarves, open jackets, baggy clothing etc. There is a risk of injury as a result of getting caught up or being drawn in.

2.3 Use as directed

1. This diesel engine has been designed exclusively for the intended use defined by the manufacturer and stipulated in the scope of delivery (use as directed): Any other form of use is not considered use as directed. The manufacturer can not be held responsible for any damage which occurs as a result. The user bears full responsibility.
2. Use as directed also includes the adherence of operating, maintenance and repair requirements prescribed by the manufacturer. The diesel engine may only be operated, maintained and repaired by persons which are familiar with these tasks and are fully aware of the dangers.
3. The manufacturer does not bear responsibility for any material damage or injury to persons which occurs as a result of unauthorised modifications to the diesel engine.

Likewise, manipulation of the injection system and servo system could influence output and exhaust characteristics of the diesel engine, whereby compliance of the legal environmental regulations can no longer be guaranteed.

2.4 Notes on the prevention of crushing and burns

1. Do not use any lifting materials, such as ropes or chains, which are damaged or do not feature sufficient lift capacity.
Always wear industrial gloves when handling wire cables.
2. Ensure that no objects come into contact with the fan while the diesel engine is running.
Objects which fall into, or protrude into, the fan will be flung back out or destroyed, and could cause damage to the fan.
3. When verging on operating temperature, the diesel engine's cooling system is hot and under pressure.
Avoid any contact with parts carrying cooling water.
Risk of burns!
4. Only check the cooling water level if the sealing cap of the expansion tank is cool enough to touch.
Open the cap carefully to relieve any excess pressure.
5. Verging on operating temperature, the diesel engine oil is hot.
Avoid skin contact with hot oil or parts carrying oil.
6. Always wear protective glasses and industrial gloves when working on the battery.
Avoid sparks and naked flames.

2.5 Notes on the prevention of fire and explosions

1. The diesel engine must be switched off when refuelling.
2. Do not smoke and avoid naked flames in the area where batteries are being recharged and when refuelling.
3. Always start the diesel engine in accordance with the operating and maintenance instructions' guidelines.
4. Check the electrical system.
Remedy all faults, such as loose connections and worn cables, immediately.
5. Check all lines, hoses and threaded unions regularly for leaks and damage.
6. Remedy leaks and replace damaged components immediately.
Oil spraying out of points which are not properly sealed is highly flammable.

2.6 Observe safety precautions when starting

1. Unless otherwise specified, always start the diesel engine in compliance with the guidelines in the “**Operating and Maintenance Instructions**”.
2. Start the diesel engine and then check all display equipment and control devices.
3. Only allow the diesel engine to run in enclosed areas if sufficient ventilation has been provided.
If necessary, open doors and windows to ensure that a sufficient supply of fresh air can be guaranteed.

2.7 Measures for safe maintenance

1. Do not carry out any maintenance or repair tasks with which you are not familiar.
2. Adhere to any intervals for recurring checks or inspections which have been prescribed or are specified in the operating instructions.
To carry out servicing measures, it is absolutely imperative that factory equipment appropriate for the respective task be used.
3. The tasks to be carried out, as well as the personnel by which these tasks must, or may be performed, are clearly defined in the listing at the end of these “**Operating and Maintenance Instructions**”.
The tasks listed under “**daily/weekly**” in the maintenance chart can be carried out by the machine operator or the maintenance personnel.
All other tasks may only be carried out by authorised personnel who have undergone the appropriate training.
4. Spare parts must comply with the technical requirements specified by the manufacturer. This can always be guaranteed with original spare parts.
5. Always wear protective clothing when carrying out maintenance tasks.
6. Unless otherwise specified in these “**Operating and Maintenance Instructions**”, all maintenance tasks to the diesel engine must be carried out on firm, even ground and with the diesel engine switched off.

7. For maintenance and repair tasks, all loosened screw connections must be tightened with the tightening torque prescribed.
8. Clean the diesel engine of oil, fuel or detergents, in particular connections and threaded unions, before commencing maintenance/repair tasks. Do not use any aggressive cleaning agents. Use fibre-free cleaning cloths. Do not use any flammable liquids for cleaning the diesel engine.
9. Before cleaning the engine with water, steam jet (high-pressure cleaner) or other cleaning agents, seal or cover all openings into which water/steam/cleaning agents should not be allowed to penetrate due to reasons of safety or functionality.
The crankcase air vent, electronics box, starter and generator are at particular risk.
Additional tasks:
 - After cleaning, remove the covers/bondings completely.
 - Inspect all fuel lines, diesel engine oil lines and hydraulic oil lines for leaks, loose connections, points of wear and damage upon completion of cleaning.
 - Remedy any determined faults immediately.
10. Observe the safety guidelines valid for the product when handling oils, greases and other chemical substances.
11. Ensure a safe and environmentally-sound disposal of fuels and consumables, as well as replacement parts.
12. Observe caution when handling hot fuels and consumables (danger of burning and scalding).
13. Always wear gloves when searching for leaks. A fine jet of liquid when pressurised could penetrate the skin.
14. Shut down the diesel engine before loosening oil lines.
15. Combustion engines may only be operated in sufficiently ventilated areas. Ensure sufficient ventilation before initiating operation in enclosed areas. Observe the valid guidelines for the respective jobsite.
16. Do not try to lift heavy parts. Suitable lifting gear featuring sufficient lift capacity must be used for these tasks.
Procedure:
 - Tighten and secure individual parts and larger assemblies carefully to the hoist when replacing heavy parts, in order that no danger is resulted.
 - Only use suitable and technically-sound hoists, as well as load carrying equipment featuring sufficient lift capacity.

It is prohibited to remain or work beneath suspended loads.
17. Do not use ropes which are damaged, or do not feature sufficient lift capacity. Always wear industrial gloves when handling wire cables.
18. Tasks to electrical equipment on the engine may only be carried out by an electrical specialist or by trained personnel under the supervision and instruction of an electrical specialist in compliance with the electrotechnical regulations.
19. Disconnect the battery when working on the electrical system and also remove the plug from the control unit if electric welding is to be carried out on the machine.
Always disconnect the negative terminal first and reconnect last.

2.8 Observe the safety precautions for diesel engines featuring electronic control units

1. Only start up the diesel engine with the batteries securely connected.
2. Do not disconnect batteries while the diesel engine is running.
3. The diesel engine may only ever be started with the control unit connected.
4. Do not use a fast charger to start the diesel engines. Only use jump leads with separate batteries.
5. The battery terminals must be removed for fast charging of the batteries. Observe the operating instructions of the fast charger.
6. When carrying out electrical welding tasks, the batteries must be disconnected and both cables (+ and —) must be securely connected with each other. Connection to the engine electronics is to be cut via both interface plugs.
7. Connections of the control units may only be connected or disconnected with the electrical system switched off.
8. Incorrect polarity of the control units voltage or supply voltage (e.g. via incorrect polarity of the batteries) can lead to ruination of the control units.
9. Tighten the connections on the injection system with the prescribed tightening torque.
10. If temperatures exceeding 80 °C (e.g. drying kiln) are expected, the control units must be removed.
11. Only use suitable test leads for measurements at the plug connections.
12. Neither sensors nor actuators may be connected individually to, or between, external voltage sources for inspection or test purposes, but rather always with the electronic control unit, otherwise there is a risk of the diesel engine malfunctioning or even becoming ruined.
13. The electronic control unit is only sufficiently protected against dust and water if the mating connector is mounted and attached. If no mating connectors have been attached, the control unit must be sufficiently protected against dust and water.
14. Telephones and radio equipment which are not connected to an exterior aerial could lead to functional failure of the vehicle's electronics, and thus jeopardise operational safety of the diesel engine.

2.9 Safety and emergency run program for diesel engines featuring electronic control units

1. The diesel engine features an electronic regulating system, which monitors the diesel engine as well as the electronic regulating system itself (self-diagnosis).

As soon as a fault is recognised, one of the following measures is automatically initiated following evaluation of the fault:

- Issue of an error report featuring error code.
- The error code is issued directly via a display in conjunction with the vehicle diagnosis system.
- Changeover to suitable back-up function for further, however limited, operation of the diesel engine (e.g. constant emergency-run speed).

Have all faults remedied immediately by the respective LIEBHERR after-sales-service department.

2.10 Disposing of fuels and lubricants

1. Ensure when handling fuels and lubricants, that no substances are spilled or poured onto the earth, into drainage systems or into bodies of water.
2. Different fuels and lubricants are to be collected and disposed of in separate containers.
3. Use sealed containers for draining fuels and lubricants. Under no circumstances should containers for food or drinks be used as the liquids could be drunk inadvertently.
4. Before recycling or disposing of waste products, enquire about the correct method at the environmental or recycling centre responsible. Incorrect disposal of waste products can harm the environment and the ecology.

3 Operation, Handling

3.1 Control elements and operating elements

The diesel engine must be operated or controlled by the following elements:

- **The electronics indicator lamp** shows the operating status of the diesel engine.
- **The oil pressure display** shows the diesel engine oil pressure
- **The ammeter or charge control lamp** shows the charging current in the electrical system
- **The coolant thermometer** shows the temperature of the diesel engine coolant
- **The tachometer** shows the diesel engine speed in rpm
- **The operating hour meter** shows the number of hours the diesel engine has been operated
The operating hour meter must be used for the scheduling of regular maintenance.
- **The air filter maintenance display** indicates the degree of contamination in the air filter.
- **The speed regulation** regulates the speed of the diesel engine

3.2 Operation

3.2.1 Preparing for initial start-up

CAUTION!

If the application site is located 3000 metres or more above sea level, the output must be reduced following consultation with the factory. If the output is not reduced, the diesel engine will become thermally overloaded and this will lead to malfunctioning.

Brand new diesel engines are delivered from the factory already filled with the oil required for initial start-up. As a rule, replacement engines and engines which have undergone a general overhaul are delivered without fuel.

The high-grade initial start-up oils assist the run-in process and allow the first oil change to be carried out at normal oil change intervals.

For filling amounts and quality, see the chapter Fuel and Lubricant Specifications.

Filling in fuels

The following fuels are to be filled in before initial start-up:

– **Diesel engine oil**

For replacement engines or engines which have undergone a general overhaul, use authorised diesel engine oil, (see the chapter Fuel and Lubricant Specifications)

– **Coolant**

For coolant composition, see the chapter, Fuels and Lubricants-Specifications.

– **Fuel**

Use summer fuel or winter fuel in accordance with the season. Diesel fuels must comply with the permissible fuel specifications, see the chapter, Fuel and Lubricants-Specifications.

– Ensure utmost cleanliness, use a funnel with sieve. When refuelling from drums or canisters, observe the safety guidelines, see the chapter, Safety Guidelines. It is imperative that the penetration of water is avoided.

The following preparations must be carried out following the filling of fuels:

- Lubricate articulated shafts, cables, ball sockets, grease nipples and ring gear with oil or grease.
- Check the batteries. Use fully charged batteries which have undergone regular maintenance only.
- Bleed the fuel system (see the chapter, Maintenance)

Tasks during and following the test-run

Bleeding the cooling system:

- Allow the diesel engine to run for approx. 5 minutes at medium speed. Then check the coolant level again and refill as necessary.
- If a heating system is connected to the cooling system, all heating valves must be opened when refilling. The heating valves may only be closed again after the diesel has been allowed to run for a short time and, if necessary, has been refilled.

Checking the diesel engine oil level:

- Check the diesel engine oil level approx. 2–3 minutes after switching off the diesel engine, if necessary refill oil up to the maximum marking on the oil dipstick.

Checking the diesel engine

- Check the diesel engine for leaks.
- Check hose clamps and pipe connections around the entire system for leaks and correct tightening, tighten as necessary.

3.2.2 Maintenance tasks before daily start-up

Before daily start-up, the maintenance tasks (daily) must be carried out every 10 operating hours (see the chapter, Maintenance).

3.2.3 Starting the diesel engine

Start procedure

Starting of the diesel engine is only permissible if you have read and thoroughly understood the operating instructions.

- If a fuel shut-off valve is available:
Open the fuel shut-off valve.
- Speed adjusting device in idle speed.
- Start the diesel engine with the ignition key or starter button.



JD000025

Operating instructions

Troubleshooting

The engine has still not started after approx. 20 seconds?

- Wait for 1 minute.
- If this measure has been repeated three times:
Determine and remedy the cause.

-
- Check the oil pressure gauge immediately after starting the diesel engine.

Troubleshooting

The oil pressure is not displayed within 5 seconds.

- Switch off diesel engine immediately.

-
- Do not subject the engine to full load immediately after starting. After a brief (10–15 sec.) spell at idle speed, allow the diesel engine to run warm at medium speed and medium load.

Operation

- Checking the diesel engine in operation.
 - Oil pressure is constant.
 - Output and speed are constant.
 - Exhaust gas is colourless.
 - Cooling water temperature is stable.
 - The sounds of the diesel engine appear normal.

Troubleshooting

Faults are determined?

- Switch off diesel engine immediately.
-

3.2.4 Precautions for starting up in icy temperatures

Low temperatures

The starting behaviour can thus be considerably improved in low temperatures:

Warning



Danger of the diesel engine exploding!

There is a serious risk of the engine exploding if ether-based starting aids are used for starting the diesel engine with preheating system!

! Refrain from using ether-based starting aids.

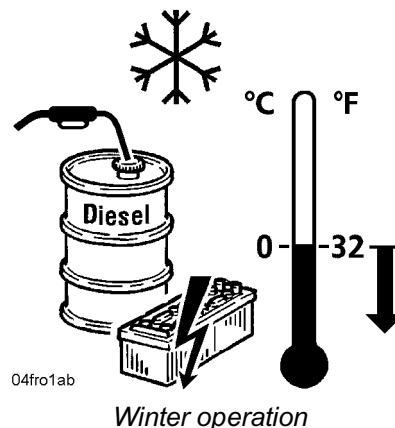

- Check the charge of the battery.
- If the battery is not sufficiently charged:
Recharge the battery.
- Use winter fuel (see the chapter, "Fuels and Lubricants" under winter operation).
- Diesel engine start procedure, see documentation of the manufacturer.

3.2.5 Shutting down

Switching off the diesel engine.



Risk of the diesel engine becoming damaged!

When switching off the diesel engine, the turbocharger continues to run briefly with no supply of oil.

! Never switch off the diesel engine directly from running at full load.

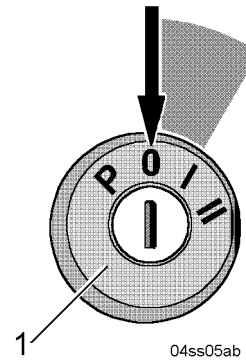

Start switch – 0-position

- Reduce the diesel engine speed to idle.
- Allow the diesel engine to continue to run briefly, approx. 10 to 15 seconds, without load in idle.
- Turn the ignition key to the **-0-** position and remove.

The diesel engine has been shut down.

Troubleshooting

If the ambient temperature in the engine compartment is unusually high. The fan is no longer rotating at full speed due to a faulty viscous coupling.

- Check the viscous coupling and replace if necessary.

4 Malfunctions

Troubleshooting can prove to be difficult for diesel engines. For possible diesel engine faults with suspected causes and remedial measures, see the Troubleshooting Chart.



Note:

Error codes are indicated on the machine display for diagnosis of the diesel engine faults. An explanation and a remedy are described in the respective machine documentation.

Fundamental logical steps for diagnosis are included in the following list:

- Knowing the diesel engine and all associated systems.
- Scrutinise the problem thoroughly.
- Relate the problem and knowledge of the diesel engine and its systems.
- Diagnose the problem, whereby the simplest assumptions are worked upon.
- Double check before beginning disassembly.
- Establish the causes and perform repair work thoroughly.
- Following repair, allow the diesel engine to run under normal operating conditions and check whether the problem and the cause have been remedied.

4.1 Error code tables

Fault	Possible cause	Remedy
Starter will not crank	Main fuse is burned out	Replace fuse
	Battery connections loose or corroded	Clean loose connections and tighten
	Battery voltage too low	Recharge or replace battery
	Starter electric circuit broken or contacts corroded	Consult LIEBHERR AFTER-SALES-SERVICE
	Starter faulty	Consult LIEBHERR AFTER-SALES-SERVICE
Starter will crank only slowly	Battery voltage too low	Recharge or replace battery
	Battery connections loose or corroded	Clean loose connections and tighten
	Ambient temperature too low	Observe the measures for winter operation
Diesel engine will not start or cuts out again shortly after starting	Fuel tank is empty	Refuel, bleed the fuel system
	Fuel filter is clogged	Replace fuel filter
	Fuel line, pre-cleaner or sieve in fuel tank is clogged	Clean and bleed the fuel system
	Fuel system or filter leaking	Seal and bleed
	Air in the fuel system	Bleed the fuel system
	Fuel not frost-resistant	Clean pre-filter, replace fuel filter; Use winter fuel
	Ambient temperature too low	Observe the measures for winter operation
Heater flange faulty (with cold temperatures)	Check heater flange and replace as necessary	
Diesel engine has difficulty starting	Leakages or insufficient pressure in the fuel low-pressure circuit	Inspection for leaks (visual inspection); to be carried out by LIEBHERR AFTER-SALES-SERVICE

LMB/01/003801/6.5/en/Version:::06.06.2005

Error code tables

Fault	Possible cause	Remedy
	Diesel engine - insufficient compression	Check compression, if not OK; Consult LIEBHERR AFTER-SALES-SERVICE
	Heater flange faulty (with cold temperatures)	Check heater flange and replace as necessary
	Fault in the electronics	Read out error memory from engine control unit, consult LIEBHERR AFTER-SALES-SERVICE
Diesel engine shuts down without warning	Power supply cuts out	Consult LIEBHERR AFTER-SALES-SERVICE
	Leakages or insufficient pressure in the fuel low-pressure circuit	Inspection for leaks (visual inspection); to be carried out by LIEBHERR AFTER-SALES-SERVICE
	Fault in the electronics	Read out error memory from engine control unit, consult LIEBHERR AFTER-SALES-SERVICE
Poor diesel engine output (output deficiency)	Fuel system faulty (clogged, leaking)	Visual inspection for leaks, replace filter, consult LIEBHERR AFTER-SALES-SERVICE
	Boost pressure too low	Loose clamps, faulty seals and hoses, air filter contaminated, turbocharger has no output
	Charge air temperature too high (automatic reduction in output by engine control unit)	Intercooler contaminated, poor fan output, ambient temperature too high, consult LIEBHERR AFTER-SALES-SERVICE
	Coolant temperature too high (automatic reduction in output by engine control unit)	Check radiator for contamination, check fan and thermostat, check coolant level, consult LIEBHERR AFTER-SALES-SERVICE
	Fuel temperature too high (automatic reduction in output by engine control unit)	Consult LIEBHERR AFTER-SALES-SERVICE
	Application area over 1800 metres above sea level	No remedy, diesel engine output was reduced automatically
	Diesel engine brake flap faulty (if available)	Functional or visual inspection; Consult LIEBHERR AFTER-SALES-SERVICE
	Injection nozzles getting stuck or not spraying	Check injection nozzles, adjust or replace, consult LIEBHERR AFTER-SALES-SERVICE
	Diesel engine - insufficient compression	Check compression, if not OK; Consult LIEBHERR AFTER-SALES-SERVICE
	Fault in the electronics	Read out error memory from engine control unit, consult LIEBHERR AFTER-SALES-SERVICE
Poor diesel engine braking action	Diesel engine brake flap not functioning	Functional or visual inspection; Consult LIEBHERR AFTER-SALES-SERVICE
	Fault in the electronics	Consult LIEBHERR AFTER-SALES-SERVICE
Diesel engine is becoming too hot (indicated on the coolant temperature display)	Insufficient coolant,	Refill
	Cooler interior contaminated or calcified, cooler exterior heavily contaminated	Clean or decalcify

Fault	Possible cause	Remedy
	Thermostat faulty	Check and replace as necessary, consult LIEBHERR AFTER-SALES-SERVICE
	Coolant temperature sensor faulty	Check and replace as necessary, consult LIEBHERR AFTER-SALES-SERVICE
	Speed of fan too low (hydrostatic fan drive only)	Check fan drive and replace wherever necessary, consult LIEBHERR AFTER-SALES-SERVICE
Charging current indicator lamp lights up when the diesel engine is running	Inadequate tension of ribbed V-belt	Check belt tension, if necessary replace tension pulley
	Ribbed V-belt torn	Replace ribbed V-belt
	Cable connections loose or disconnected	Secure or replace cable
	Alternator, rectifier or governor faulty	Check; Consult LIEBHERR AFTER-SALES-SERVICE
Diesel engine emitting black smoke	Injection nozzles getting stuck or not spraying	Check injection nozzles, adjust or replace, consult LIEBHERR AFTER-SALES-SERVICE
	Diesel engine brake flap faulty	Functional or visual inspection; Consult LIEBHERR AFTER-SALES-SERVICE
	Turbocharger faulty (boost pressure too low)	Check functioning of turbocharger; consult LIEBHERR AFTER-SALES-SERVICE
Exhaust gases are blue in colour	Oil level in diesel engine too high	Ensure correct oil level
	Lube-oil is entering the combustion chamber and is being burned.	Consult LIEBHERR AFTER-SALES-SERVICE
	Seals on the compressor side on the exhaust turbocharger faulty	Check exhaust turbocharger, replace as necessary; Consult LIEBHERR AFTER-SALES-SERVICE
	Crankcase breather faulty	Check and replace as necessary
Exhaust gases are white in colour	Injection begin too late	Consult LIEBHERR AFTER-SALES-SERVICE
	Heater flange faulty (with cold temperatures)	Check heater flange and replace as necessary
Diesel engine knocking	Combustion disorder	Consult LIEBHERR AFTER-SALES-SERVICE
Diesel engine rattling	Valve clearance too big	Adjusting valve clearance
	Injection nozzles faulty or carbonised	Check injection nozzles, adjust or if necessary replace, consult LIEBHERR AFTER-SALES-SERVICE
	Damaged bearings	Consult LIEBHERR AFTER-SALES-SERVICE
	Piston rings worn or broken, pistons eroded	Consult LIEBHERR AFTER-SALES-SERVICE
Irregular noises	Leakages at the induction pipe and exhaust gas pipe cause whistling noises	Remedy leakages, if necessary replace seal
	Rubbing of turbine wheel or compressor impeller on the housing; Foreign bodies in compressor or turbine; Seized bearing of rotating parts	Replace turbocharger; consult LIEBHERR AFTER-SALES-SERVICE
Insufficient lube-oil pressure	Oil level in the oil sump too low	Fill in oil to prescribed level
	Viscosity of lube-oil too low (thinning of oil due to diesel fuel)	Drain oil, fill in prescribed oil

LIEBHERR/01/003801/16.5/en/Version:::06.06.2005

Error code tables

Fault	Possible cause	Remedy
	Oil pressure gauge or pressure sensor faulty	Check oil pressure and replace faulty oil sensor or pressure gauge; Consult LIEBHERR AFTER-SALES-SERVICE
	Final check valve not functioning correctly or dirt in final check valve	Check final check valve, clean or replace and reset; Consult LIEBHERR AFTER-SALES-SERVICE
	Bearing clearance too great due to wear or bearing damaged	Remount engine or carry out over-haul;consult LIEBHERR AFTER-SALES-SERVICE
Lube-oil in the cooling system	Oil cooler or oil cooler grill leaking	Conduct pressure test, replace if leaks are determined; Consult LIEBHERR AFTER-SALES-SERVICE
Cooling water in the lube-oil	O-rings on the cylinder liners not tight	Replace O-rings; Consult LIEBHERR AFTER-SALES-SERVICE
	Oil cooler or oil cooler grill leaking	Conduct pressure test, replace if leaks are determined; Consult LIEBHERR AFTER-SALES-SERVICE

5 Maintenance

5.1 Maintenance and inspection schedule

Abbreviations used in this section:

Bh = Operating hours

BA = Operating instructions

WH = Service handbook

AFP = Authorised, trained personnel

WP = Maintenance personnel

Different symbols(circle, box – filled or circle, box – blank) divide the maintenance tasks into two groups.

Meaning of symbols:

- Circle, box – filled out means that the machine operator or his maintenance personnel must carry out the maintenance tasks independently.

The maintenance intervals correspond to: every 10 and 50 operating hours (Bh)

- Circle, box – blank means that the specialist personnel authorised by the LIEBHERR company, or their appointed dealers, must carry out or supervise the maintenance and inspection tasks.

The maintenance intervals apply: upon commissioning and every 400, 800, operating hours (Bh)

Customer: Machine type: Serial No.: Oper. hours: Date

Maintenance/inspection according to operating hours						Special intervals	TASKS TO BE PERFORMED	
On delivery	Every 10	Every 50	Every 400	Every 800	By maintenance personnel ■ One-off activity ● Repetition interval † If necessary ❄ Annually at the start of the cold season		By authorised qualified personnel □ One-off activity ○ Repetition interval † If necessary	
Diesel engine								
●	●	○	○				Checking the oil level	
●	●	○	○				Visual inspection (contamination, damages)	
		○	○				Checking the diesel engine brake	
		○	○				Change or replace diesel engine oil: CAUTION, the operating hours specified are only valid with the appropriate lube-oil quality / difficulty factors see Fuel and Lubricants	
		○	○				Replace the oil filter	
		○	○				Checking batteries and cable connections	
		○	○				Check ribbed V-belt	
		□	○				Checking the induction and exhaust system for sound condition and for leaks	
			○				Lubricate ring gear on the flywheel	
			○				Checking the oil sump and diesel engine bracket for secure seating	
			○			❄	Checking the flame-type kit	
						†	Replace the oil separator (or at the latest, every 2 years)	
Cylinder head								
		○	○				Checking / adjusting valve clearance	
Cooling system								
●	●	○	○				Check coolant level and (if featured, coolant level sensor)	
		○	○				Checking the cooling system for leaks and for sound condition	
						❄	Checking anticorrosive and antifreeze in the coolant	
					3200h		Replace coolant (or at the latest, every 2 years)	
						†	Degreasing the cooling system	
						†	Decalcify and derust cooling system	
Fuel system								
●	●	○	○				Check water separator on the fuel pre-filter and drain water as required	
	●	○	○				Draining water and sediment in the fuel tank	
		○	○				Checking the oil system and fuel system for leaks and for sound condition	
			○				Replace the fuel pre-filter and clean or replace the pre-filter insert	
			○				Replacing the fuel fine filter	
						†	Bleed fuel system	
Air filter system								
●	●	○	○				Air filter low-pressure display	
	●	○	○				Cleaning the dust-discharge valve of the air filter	

LMB/01/003801/6.5/en/Version::06.06.2005



Customer: Machine type: Serial No.: Oper. hours: Date

Maintenance/inspection according to operating hours						Special intervals	TASKS TO BE PERFORMED	
On delivery	Every 10	Every 50	Every 400	Every 800	By maintenance personnel		By authorised qualified personnel	
						<ul style="list-style-type: none"> ■ One-off activity ● Repetition interval ✦ If necessary * Annually at the start of the cold season 	<ul style="list-style-type: none"> □ One-off activity ○ Repetition interval ◇ If necessary 	
					◇	Replace dry air filter main element (in accordance with maintenance display / yearly)		
					◇	Replace dry air filter safety element (with every third replacement of the main element / yearly)		

LMB/01/003801/6.5/en/Version::06.06.2005

5.2 Lubricant chart, Filling quantities

5.2.1 Table of filling quantities

	Name	Medium	Dosage	Units
 06sy04ab	Diesel engine (without water cooler)	Coolant	13	Litres
 06sy05ab	Diesel engine (with oil filter)	Oil	approx. 33	Litres

5.2.2 Lubricant chart

The maintenance chart serves as a summary for the location of maintenance points on the diesel engine and the maintenance interval periods.

Detailed information can be obtained in the section "Maintenance and Inspection Chart", as well as in the individual descriptions regarding the carrying out of maintenance tasks, see the section, "Maintenance tasks...".

For detailed information regarding the necessary fuels and lubricants, see the section, "Fuels and Lubricants".

For information regarding the necessary filling amounts, "see the section, Filling Amounts Chart".

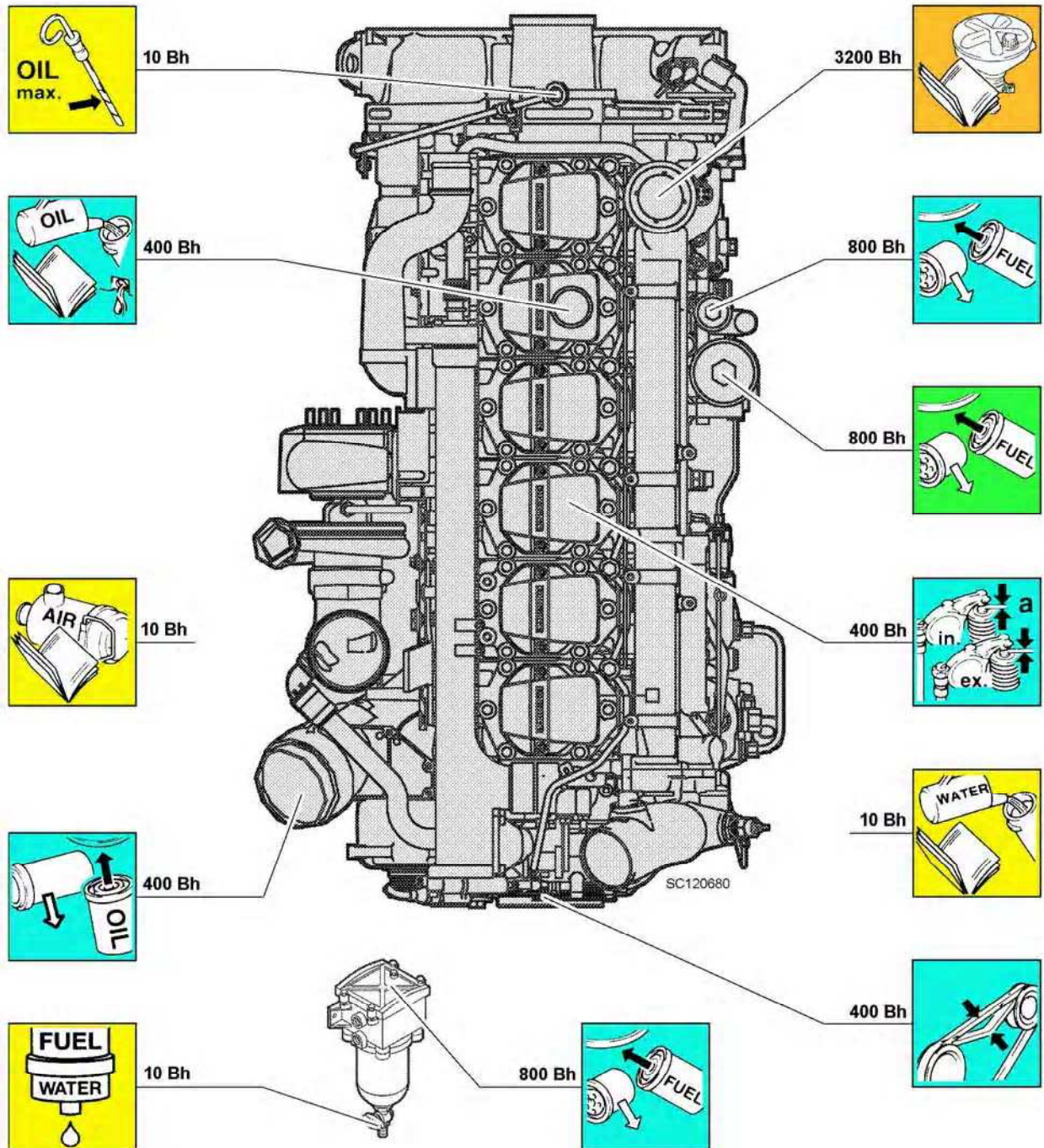

LMB/01/003801/6.5/en/Version::06.06.2005

5.3 Maintenance tasks

5.3.1 Special tools for maintenance tasks

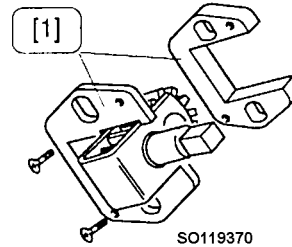

Engine turning gear — special tool no. 1

No.	Ident. no.	Model	See section
1	10017187	Engine turning gear	Checking / adjusting valve clearance

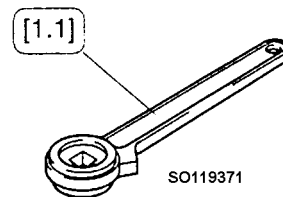

Reversible ratchet — special tool no. 1.1

No.	Ident. no.	Model	See section
1.1	10017185	Reversible ratchet	Checking / adjusting valve clearance

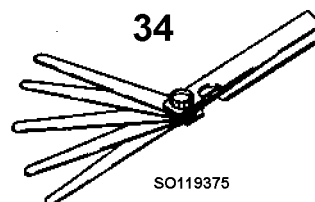

Feeler gauge — special tool no. 34

No.	Ident. no.	Model	See section
34	10017189	Feeler gauge	Checking / adjusting valve clearance

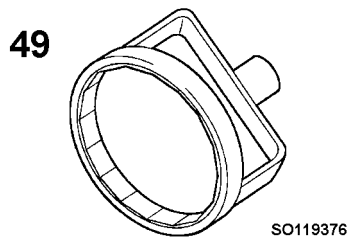

Oil filter wrench — special tool no. 49

No.	Ident. no.	Model	See section
49	10017191	Oil filter wrench	Replace the oil filter

5.3.2 Preparatory tasks for maintenance

Before carrying out diverse maintenance tasks, the diesel engine, unless otherwise expressly specified in the description, must be brought into the maintenance position.

Diverse maintenance tasks are for example:

- Checking of the oil level or oil-change
- Replacing the filter, as well as adjustment or repair tasks.

Safety precautions for maintenance

It is imperative that the safety guidelines are observed when carrying out maintenance tasks! See the chapter, Safety Guidelines

Maintenance points

The diesel engine is in the maintenance position when:

- the diesel engine is positioned horizontally,
- the diesel engine is switched off,
- the diesel engine is cooled,
- the battery main switch (if featured) is switched off and the key for the battery main switch has been removed.

5.3.3 Maintenance tasks (daily) every 10 operating hours

It must be ensured that:

- the diesel engine is in the maintenance position
- the diesel engine is warm
- a collecting vessel has been prepared

Checking the oil level

The oil dipstick is on the left-hand or right-hand side of the diesel engine depending on the design, and the oil filler nozzle is located on the cylinder head cover.

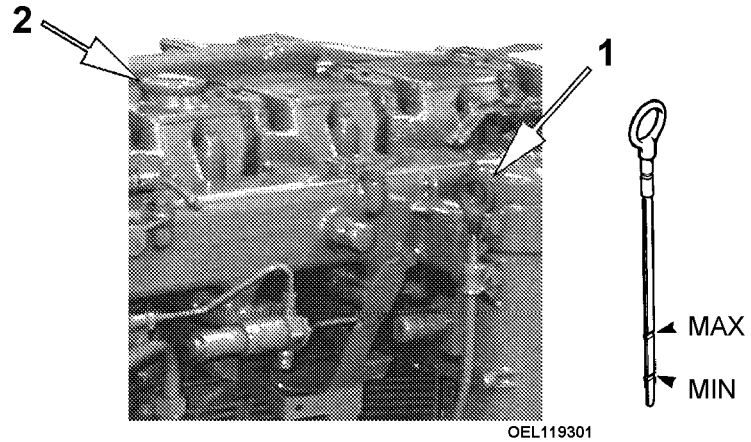

Oil dipstick - oil filler nozzle

- Remove the oil dipstick **1** completely, wipe thoroughly and reinsert after approx. 30 seconds.

**Note:**

Should the oil dipstick become stuck upon reinsertion, twisting the oil dipstick will enable you to insert the oil dipstick further .

- Pull out the oil dipstick once again and determine the oil level.

The oil level must be within min and max.

Troubleshooting

It has been determined that the oil level is too low:

- Fill in oil via the oil filler nozzle **2** (for oil quality, see the chapter "Fuel and Lubricants").

Do not refill above the upper marking max. of the oil dipstick.

- Clean the oil filler cap, replace onto the oil filler nozzle and tighten.

Checking the coolant level

The coolant level externally indicated via the transparent expansion tank. Machines featuring non-transparent expansion tank: Check the coolant level in the filler neck, if the level is correct the coolant is visible.

Procedure**Caution**

Danger of scalding as a result of coolant being squirted out!

! Only open the sealing cap **1** on the expansion tank when the diesel engine has cooled - the coolant temperature display on the segment field of the display unit should be in the lower third of the segment field.

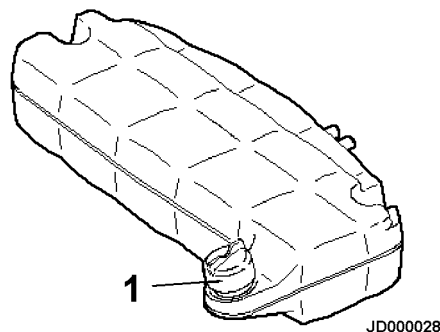

JD000028

Coolant expansion tank

- Check coolant level, see documentation of the manufacturer.

Troubleshooting

It has been determined that the oil level is too low:

- Do not start the diesel engine.
- Turn the sealing cap on the expansion tank slightly anticlockwise until the excess pressure is dissipated, then open.

- Only fill in prepared coolant with 50 vol.– % anticorrosive/antifreeze at the expansion tank (for coolant, see the chapter “Fuel and Lubricants”).
- Fill cooling system to maximum level.
- Remount the sealing cap on the expansion tank and tighten.
- Start the diesel engine and allow to run warm.
- Check the coolant level again and top up as required.

Ensure that the coolant contains at least 50% anticorrosive / antifreeze (coolant, see the chapter “Fuel and Lubricants”).

Check air filter low-pressure display

For installation position and design of the air filter low-pressure display, see documentation of the manufacturer.

When the maximum permissible low pressure is reached, the mechanical air filter low-pressure display on the purified air connection of the air filter is in the red area or, with an electrical maintenance display, the indicator lamp lights up.

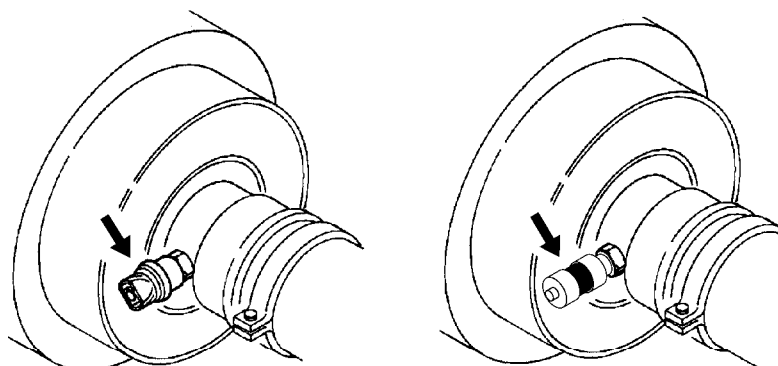

JD000010

Air filter low-pressure display

- Checking the air filter low-pressure display

Troubleshooting

If a display is in the red area, or if an indicator lamp is lit:

- Do not start the diesel engine.
- **The air filter safety element may not be cleaned.**
Clean or replace the air filter main element.

• Tasks to be carried out in accordance with the documentation of the manufacturer.

- If a reset button of the air filter low pressure display is available:
After carrying out maintenance of the air filter, push in the reset button and release.

The display is reset in green.

Checking / draining the water separator of the fuel pre-filter

Assembly of the fuel pre-filter with water separator is mounted at a sufficient distance from the diesel engine.

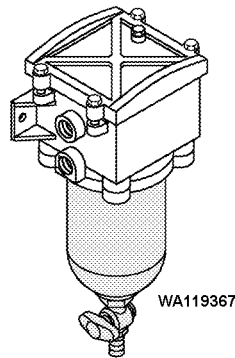

Fuel pre-filter with water separator

Fuel pre-filter with water separator

Danger



Risk of fire and explosion!

- ! No smoking.
- ! Avoid naked flames.
- ! Only work on the diesel engine while the diesel engine is switched off.

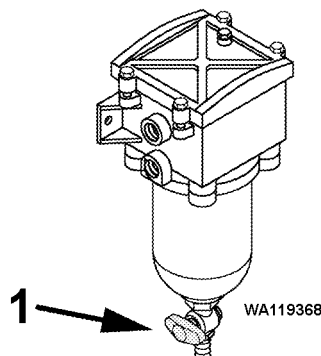

Draining the fuel pre-filter

- Check water separator of the fuel pre-filter

Troubleshooting

Should water be determined in the water separator of the fuel pre-filter:

- Do not start the diesel engine.
- Position a collecting vessel beneath the fuel water separator and, if necessary, attach a drainage hose..
- Push in the drain tap handle **1** and turn in an anticlockwise direction, drain water until fuel flows out.
- When fuel begins to flow:
Close drain tap 1.

**Visual inspection
(contamination, damages)**

Sealing points which are exuding only insignificant amounts of water may be overlooked.

- Check the diesel engine for leaks via visual inspection.

Troubleshooting

Should water in the oil, major leaks with continuous oil loss or a damaged water separator be determined:

A damaged oil separator, e.g. dented cover, oil vapour escaping at the diaphragm ventilation¹, impairs functioning.

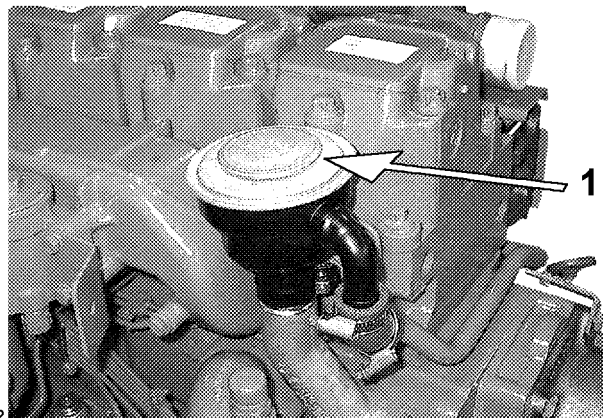

OEL119302

Oil separator

- Replace the oil separator and remedy any leaks immediately.
- Check lines and hoses for leaks via visual inspection.
- Ensure sound condition without indication of damage, correct arrangement without the occurrence of wear and correct fastening of all lines and hoses.

5.3.4 Maintenance tasks (daily) every 50 operating hours

Before carrying out weekly maintenance tasks, the daily maintenance tasks must first be carried out.

See the section "Maintenance Tasks (daily), every 10 operating hours".

It must be ensured that:

- the diesel engine is in the maintenance position

Draining water and sediment in the fuel tank

Ensure utmost cleanliness.



Risk of fire and explosion!

- ! No smoking.
- ! Avoid naked flames.
- ! Only work on the diesel engine while the diesel engine is switched off.

- Do not drain fuel onto the ground, use a suitable collecting vessel.
- Draining water and sediment in the fuel tank, see “manufacturer’s documentation”.
- When refuelling, maintain the level of fuel as high as possible in the tank, in order that condensation be reduced to a minimum.

Cleaning the dust-discharge valve of the air filter

Maintenance of the air filter is not generally required if this is indicated for example by the maintenance display on the air filter or via an indicator lamp for filter maintenance.

Important:

A damaged or hardened dust-discharge valve renders functioning of the service cover ineffective, resulting in reduced life-expectancy of the filter elements.

- Press the rubber lip on the dust-discharge valve repeatedly to empty the service cover.
- Empty the dust-discharge valve regularly when working in extremely dusty conditions.

Troubleshooting

The dust-discharge valve is damaged or is stuck in the open position:

- Replace the dust-discharge valve.

5.3.5 Maintenance tasks every 400 operating hours

Before carrying out the 400 operating hours maintenance tasks:

- carry out the daily maintenance tasks, see the section “Maintenance Tasks (daily), every 10 operating hours”.
- carry out the weekly maintenance tasks, see the section “Maintenance Tasks (weekly), every 50 operating hours”.

5.3.6 Diesel engine

It must be ensured that:

- the diesel engine is in the maintenance position

Changing diesel engine oil and replacing the oil filter element

The oil drain valve is mounted on the diesel engine, on the side of the oil sump.

The oil filter is mounted in an upright position on the front right-hand side of the diesel engine.

It must be ensured that:

- the diesel engine is positioned horizontally
- the diesel engine is switched off
- the diesel engine is warm
- a special tool no. 49 is on-hand
- an original LIEBHERR oil filter element with seals (1,2,3) has been provided
- a suitable container featuring approx. 40 l volumetric capacity, as well as a suitable oil drainage hose for the oil drain valve and diesel engine oil in compliance with the oil specification, have been provided

Draining the diesel engine oil

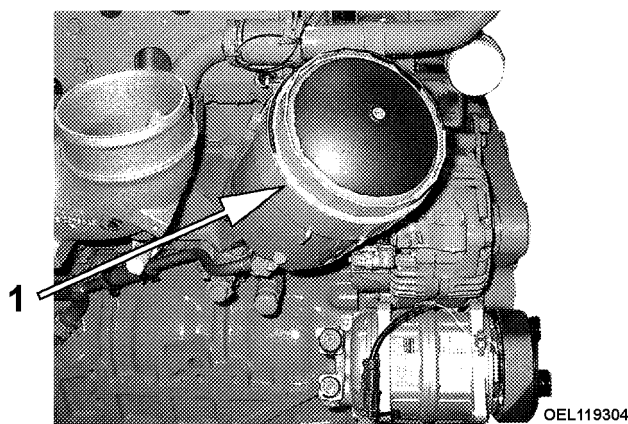

- Unscrew the oil filter cover 1 using special tool no. 49 until the upper O-ring becomes visible.

The diesel engine oil from the oil filter flows back into the oil sump.

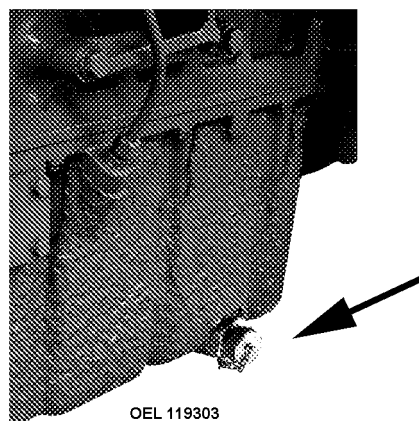

Oil drain valve

- Unscrew the sealing cap on the oil drain valve on the oil sump.
- Screw the oil drainage hose onto the oil drain valve, the oil drain valve opens.

- Drain used oil into the prepared container.

Replacing the oil filter element

- Remove oil filter cover 5 with oil filter element
- Remove the old oil filter element 4 from the cover and ensure proper disposal. Observe the safety guidelines in order that environmental damage is avoided.

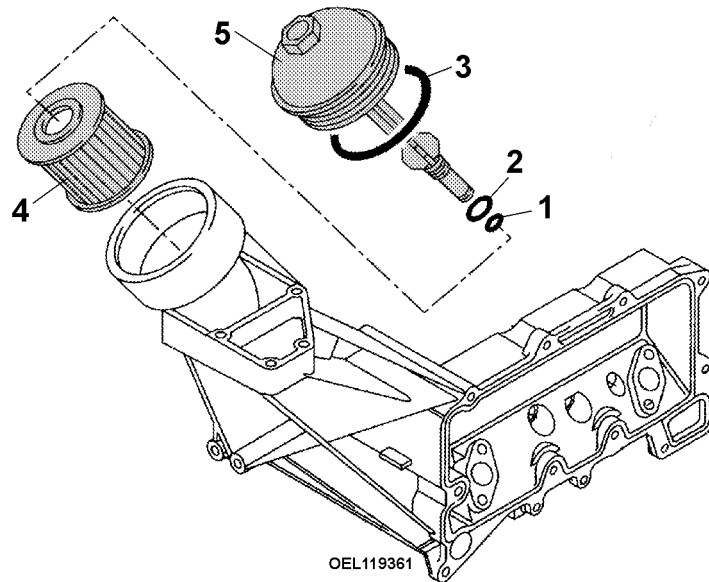

- Insert the new sealing rings 1,2,3 .
- Install the new oil filter element 4 .
- Screw in the new oil filter cover 5 with oil filter insert and tighten with 25Nm.

Filling in diesel engine oil

- Unscrew the oil drainage hose and screw the sealing cap onto the oil drain valve

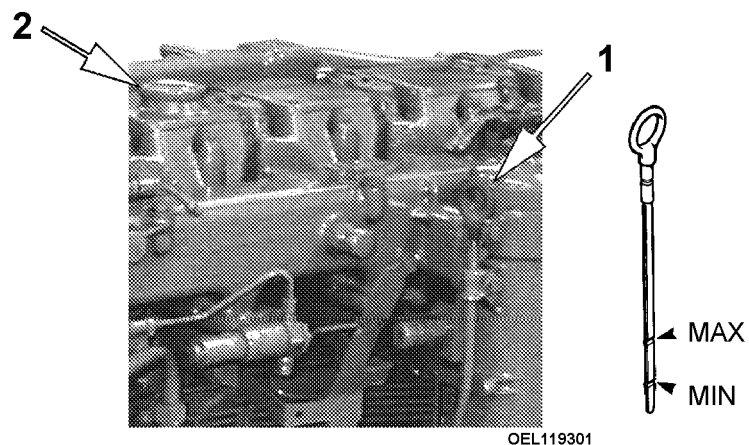

Diesel engine-oil filler nozzle

- Fill in oil via the oil filler nozzle **2** to within the min. and max. markings on the oil dipstick **1**.
- Clean the oil filler cap, replace onto the oil filler nozzle and tighten.
- Start the diesel engine.
- Check oil pressure (diesel engine oil pressure display unit) and check seals on the oil filter.
- Switch off diesel engine.
- Check the oil level after 2 - 3 minutes on the dipstick.

Troubleshooting

The oil level is not within min. and max.?

- Rectify the oil level.
-

Checking condition of / replacing the ribbed V-belt

The ribbed V-belt with automatic tensioning device is at the front of the diesel engine. Running of the ribbed V-belt varies depending on the diesel engine dimensions, e.g. with generator drive or generator drive with air-conditioning compressor.

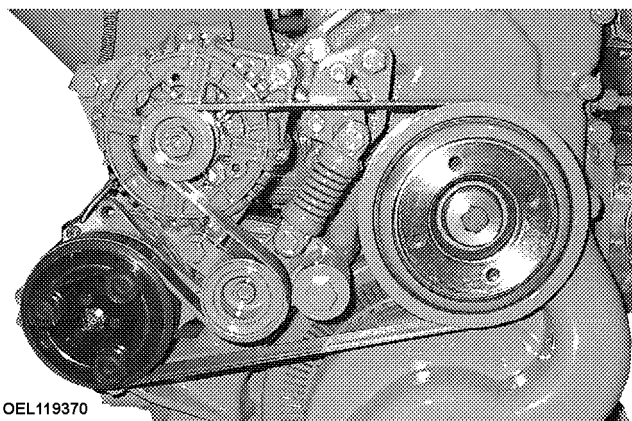

Generator drive with air-conditioning compressor

It must be ensured that:

- a new ribbed V-belt is on-hand.

Damages to the ribbed V-belt include:

- Rib fractures
- Transversal fractures in several ribs
- Rubber nodules in between the ribs
- Deposition of dirt or stones
- Ribs becoming loosened at the base of the ribs
- Transversal fractures on the belt exterior

- Check the ribbed V-belt for damage

Troubleshooting

Damage has been determined?

- Replace the ribbed V-belt

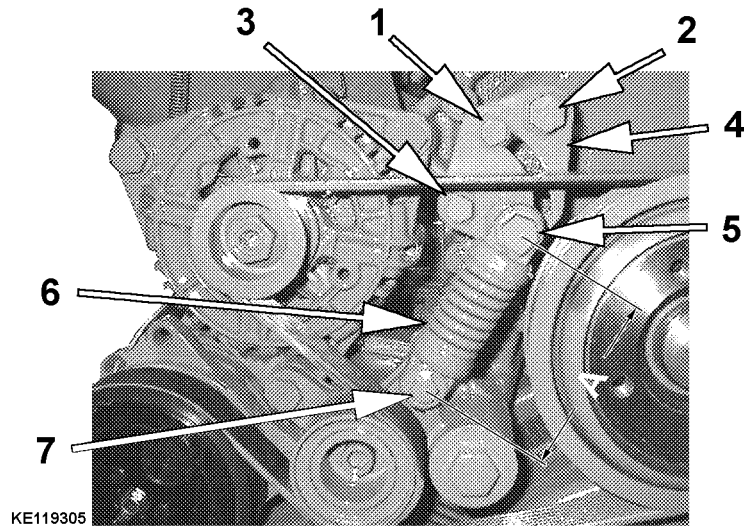

Ribbed V-belt generator drive with air-conditioning compressor

Note:

In order that damage to the spring damping element **6** can be avoided, applying and relieving tension in the spring damping element must be resulted **slowly**. Under no circumstances should the spring damping element be permitted to “spring back”.

- Apply ring spanner SW 19 to the retainer **2** (observe rotational direction of the tensioning plate **4** — danger of crushing!)

- Loosen screw **1** and screw **7**

then

- Loosen screw **3**, holding the retainer firmly with the ring spanner and relieve tension in the damper **6** **slowly**.
- Remove the old ribbed V-belt
- Ensure sound condition of tension pulley, belt pulley and damper (e.g. check bearing of tension pulley, as well as the profile of the belt pulley for wear).

If parts are damaged, replace the parts

- Mount new ribbed V-belt on all belt pulleys and tension pulleys.
- Securing the retainer firmly with the ring spanner, apply tension slowly to the tensioning plate observing the tension clearance.
- Tighten screw **1** and screw **3** hand-tight.

Has the tensioning clearance reached $A = 91.5 \pm 1$ mm from the screw head centre to the screw head centre of the damping unit ?

- Tighten screw **1**, **3** and screw **7**.

Checking / adjusting the ribbed V-belt tensioning device

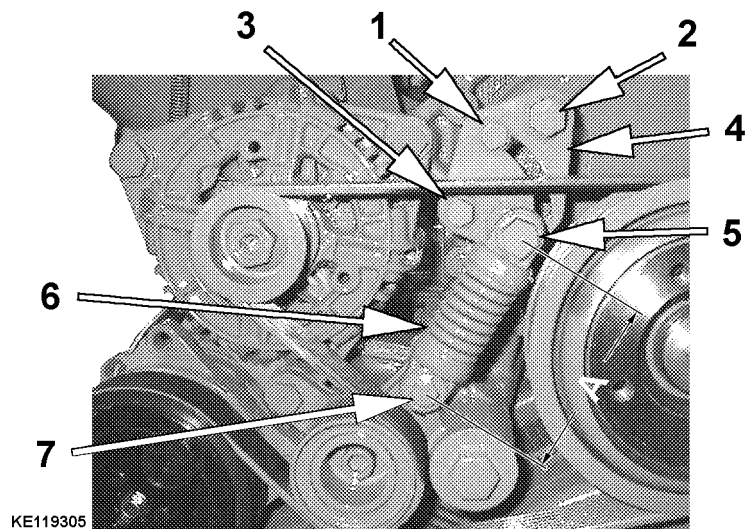

Pretension of the ribbed V-belt

The automatic ribbed V-belt tensioning device is comprised of a spring damping element, for which a basic position must be set.

Pretension to the automatic ribbed V-belt tensioning device is correct when the dimension $A = 91.5 \pm 1 \text{ mm}$.

- Check setting dimension A from centre of screw head to centre of screw head.

Troubleshooting

If the result of the measurement does not comply with the prescribed dimension $A = 91.5 \pm 1 \text{ mm}$

- The ribbed V-belt tensioning device is set as follows.

Note:

In order that damage to the spring damping element **6** can be avoided, applying and relieving tension in the spring damping element must be resulted **slowly**. Under no circumstances should the spring damping element be permitted to “spring back”.

- Apply ring spanner SW 19 to the retainer **2** (observe rotational direction of the tensioning plate **4** — danger of crushing!)
- Loosen screw **1** and screw **7**
- Loosen screw **3**, holding the retainer tightly with a ring spanner and apply or relieve tension in the spring damping element **6** **slowly** paying attention to tensioning clearance tension A.
- Tighten screw **1**, **3** and screw **7**.

Has the tensioning clearance reached $A = 91.5 \pm 1 \text{ mm}$ from the screw head centre to the screw head centre of the damping unit ?

- Tighten screw **1**, **3** and screw **7**.

Checking the diesel engine brake

The diesel engine brake is mounted on the turbocharger on the right-hand side of the diesel engine.

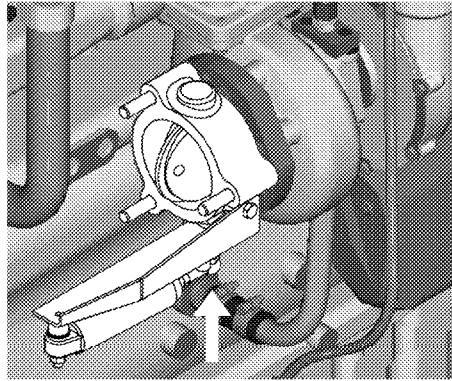

MB118556

Diesel engine brake – flap

- Check and oil the joints of the actuating cylinder.
- Actuate the brake flap.

Ensure that the flap returns correctly into the starting position following actuation.

This can be observed on the outside of the brake flap shaft, see arrow (fig. diesel engine brake – flap). The notch must be positioned parallel to the exhaust pipe.

The flap becoming stuck will cause overheating of the diesel engine, an increase in fuel consumption and thick smoke being emitted from the exhaust

Checking batteries and cable connections

- Only use fully charged batteries which have been maintained. Maintenance, see manufacturer's documentation.
- Coat the terminals with acid-proof grease (terminal grease).
- Ensure sound condition without indication of damage, correct arrangement without the occurrence of wear and correct fastening of all electrical lines.

Should damaged lines be determined?

Replace faulty lines or cable harnesses.

5.3.7 Cylinder head

A retightening of the cylinder head bolts is not required within the parameters of the maintenance work.

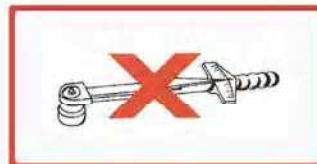

NA120685

The information plate is mounted on one of the cylinder head bolts.

Preparation for checking and adjustment of valve clearance

It must be ensured that:

- the diesel engine is in the maintenance position,
- the diesel engine is lukewarm (below 50° C),
- special tool nos. 1, 1.1, and 34 are on-hand.
- new seals for the cylinder head cover are on-hand.
- Adjustment values for 4-valve cylinder heads, see plate represented below, mounted on one of the valve covers, see also "Technical Data".

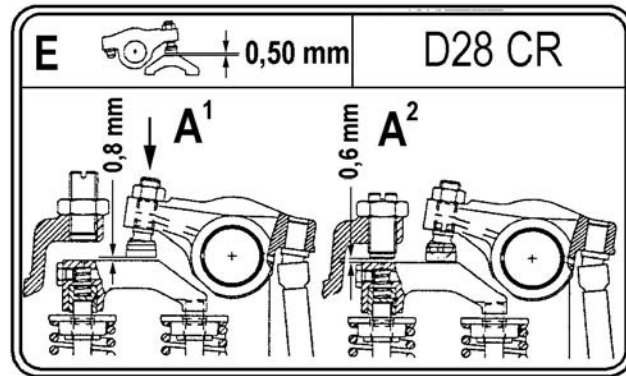

Test clearance/adjustment clearance

E = Intake valve fitting/rocker arm = 0.5 mm

A² = Exhaust valve fitting/retainer = 0.6 mm

A¹ = Exhaust valve fitting/rocker arm = 0.8 mm

Carry out valve clearance test only when diesel engine has cooled enough to touch.

Note:

- Cylinder 1 on the side opposite the flywheel
- Rotational direction on the left-hand side looking at the flywheel
- Exhaust valve of the respective cylinder on the flywheel side

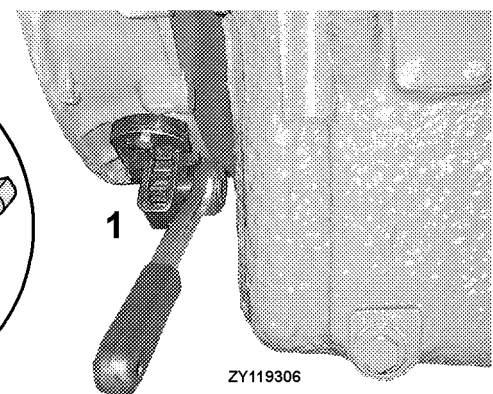
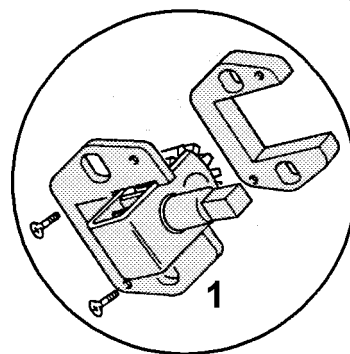

Turning gear

LMB/01/003801/6.5/en/Version::06.06.2005

- Dismantle the cylinder head cover, mount the turning gear, special tool no. 1, on the flywheel housing
- Turn the crankshaft in the direction of rotation until the cylinder to be adjusted overlaps the opposite valve.

See table for details:

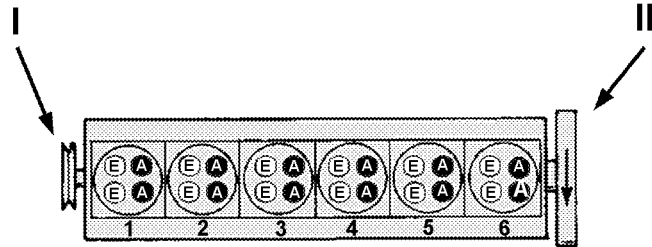

Valves of the cylinder

- I = the side opposite the flywheel
- II = the flywheel side of the diesel engine
- A = Exhaust valve
- E = intake valve

Valves of the cylinder						
overlap	1	5	3	6	2	4
adjust	6	2	4	1	5	3

Checking and adjusting the valve clearance with engine auxiliary brake system (ZBS)

Checking / adjusting intake valve clearance:

Both intake valves are actuated from a rocker arm via a jumper.

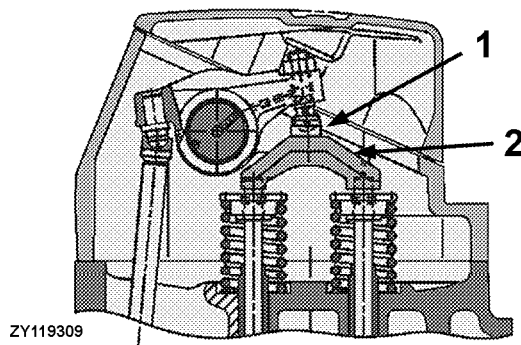

Checking / adjusting intake valve clearance

- Insert feeler gauge between pressure screw 1 and intake valve fitting 2 and check valve clearance

LMB/01/003801/6.5/en/Version:::06.06.2005

Troubleshooting

If the clearance does not comply with the adjustment values, see "Technical Data"

- Loosen the lock nut on the adjusting screw of the respective rocker arm and correct the adjustment.
- Tighten lock nut with 45 Nm

- Check adjustment again

Checking exhaust valve clearance:**Note:**

For all checks, the valve fittings must be pushed all the way down to the stop.

Ensure that the valve fitting and the bearing face of the adjusting screws do not tilt, otherwise the feeler gauge becomes jammed and the resulting measurement will be incorrect.

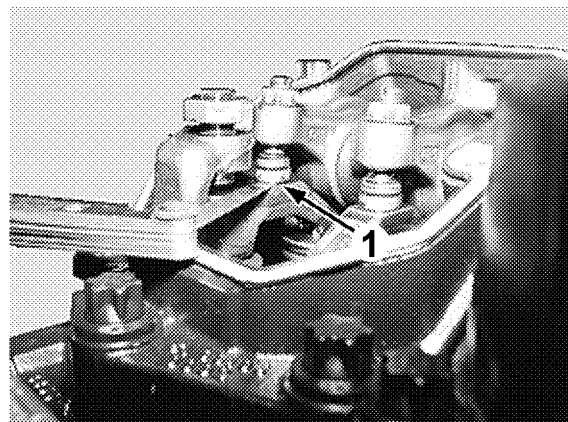

ZY119310

Checking exhaust valve clearance

- Insert the feeler gauge between valve fitting and adjusting screw—rocker arm **1** and check the valve clearance, adjust as required

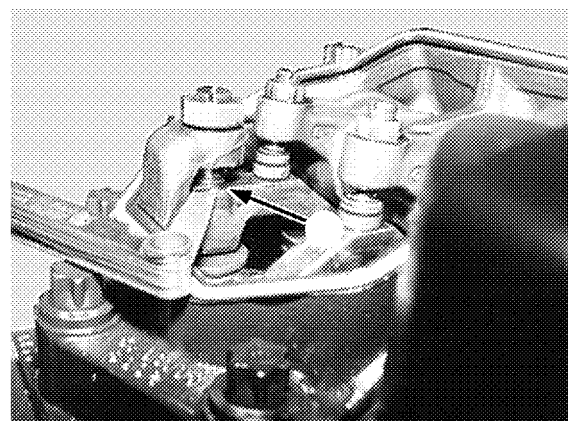

ZY119311

Checking exhaust valve clearance

- Insert the feeler gauge between valve fitting and adjusting screw—retainer **2** and check the valve clearance, adjust as required

Adjusting exhaust valve clearance:

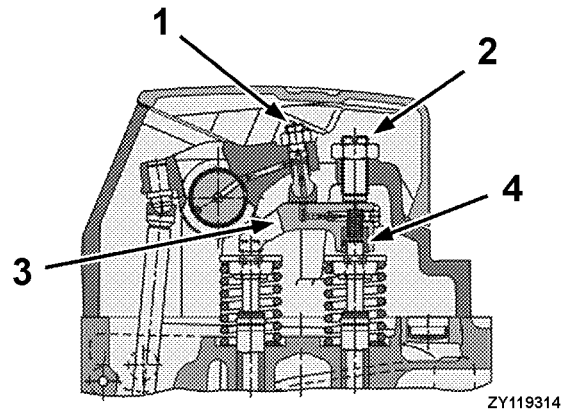

Exhaust valves

- 1 Adjusting screw, rocker arm-valve fitting
- 2 Adjusting screw, retainer-valve fitting
- 3 Valve fitting
- 4 Piston

Note:

The adjusting screw for ZBS differs from the adjusting screw for the intake valve via a lateral bore.

With the ZBS, never use screws without lateral bore.

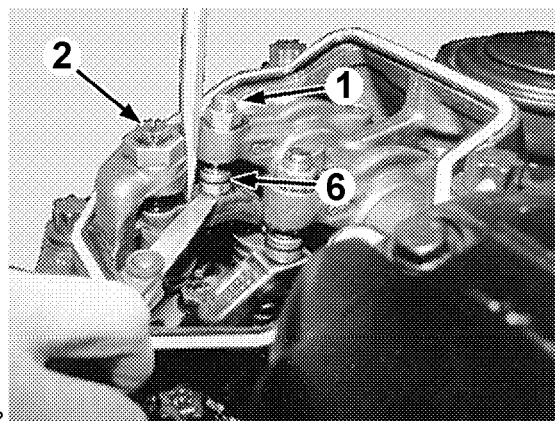

Adjusting the exhaust valve clearance

- Turn back the adjusting screw **2** until the contact face of the adjusting screw disappears inside the retainer.
- Turn back the adjusting screw **1** until it becomes possible to insert the feeler gauge 0.80 mm.
- Screw in the adjusting screw **1** until the piston in the valve fitting reaches the stop and the feeler gauge becomes clamped

If the residual oil is forced out of the ball socket-rocker arm / elephant foot **6**.

- Loosen the adjusting screw **1** until the feeler gauge can be withdrawn against moderate resistance (suction).
- Tighten the lock nut with 45 Nm.

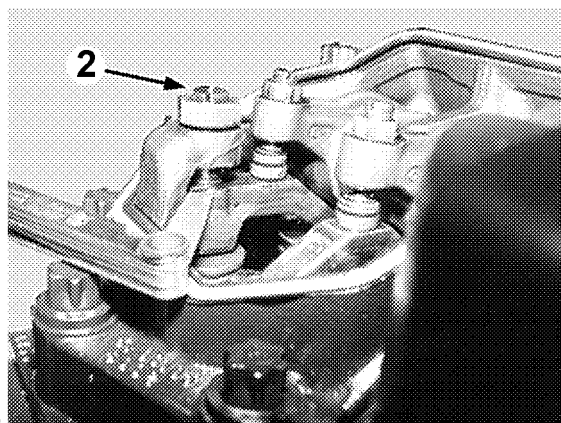

Adjusting the exhaust valve clearance

- Screw in the adjusting screw **2** with feeler gauge inserted 0.60 mm until the piston of the valve fitting reaches the stop and the feeler gauge becomes clamped.
- Loosen the adjusting screw **2** until the feeler gauge can be withdrawn against moderate resistance (suction).
- Tighten lock nut with 45 Nm.

Note:

Turn the push rod to check whether adjustment was successful, the push rod must indicate clearance.

- Following adjustment of all valves, fit cylinder head covers with new seals.

Ensure when mounting the valve cover that the seal **5** is sitting correctly in the opening of the control cable for the injector.

•

5.3.8 Cooling system

Checking the cooling system for leaks and for sound condition

- Check cooler, coolant pump and heat exchanger for the heating system for leaks.
- Check all lines and hoses of the cooling and heating system for leaks, ensure that they are correctly arranged without abrading one another and that they are free of damage.
- The washers should not become clogged with dirt. Check cooler for external contamination.

Troubleshooting

Determine any leaks in the cooling system:

- Do not start the diesel engine.
 - Determine and remedy the cause.
-

Checking anticorrosive and antifreeze in the coolant

The coolant is to be checked for effectiveness if corrosion protection and frost protection is to be guaranteed.

- Run the diesel engine warm
- Open the sealing cap of the filler neck
- Suck in the coolant with the hydrometer and read off the coolant density on the float.

Should the analysis indicate insufficient antifreeze, the mix ratio is to be corrected, see the section Fuels and Lubricants.

- Close the sealing cap of the filler neck.
- Run the diesel engine to operating temperature, whereby the thermostat must have opened at least once.
- Check anticorrosive and antifreeze in the coolant again.

5.3.9 Oil system and fuel system**Checking the oil system and fuel system for leaks and for sound condition**

- Check oil sump, oil filter, as well as high-pressure pump and fuel filter for leaks.
- Check all lines and hoses of the oil and fuel systems, ensure that they are correctly arranged without abrading one another, are free of damage and are securely fastened.

Troubleshooting

Determine any leaks in the oil and fuel system:

- Do not start the diesel engine.
- Determine and remedy the cause and replace any damaged parts.

5.3.10 Maintenance tasks every 800 operating hours

Before carrying out the 800 operating hours maintenance tasks:

- carry out the daily maintenance tasks, see the section “Maintenance Tasks (daily), every 10 operating hours”.
- carry out the weekly maintenance tasks, see the section “Maintenance Tasks (weekly), every 50 operating hours”.
- carry out the 400 operating hours maintenance tasks, see the section “Maintenance Tasks, every 400 operating hours”.

5.3.11 Diesel engine

Lubricating the ring gear on the flywheel

The maintenance cover is on the right-hand side of the diesel engine on the underside of the flywheel housing.

It must be ensured that:

- the diesel engine is in the maintenance position

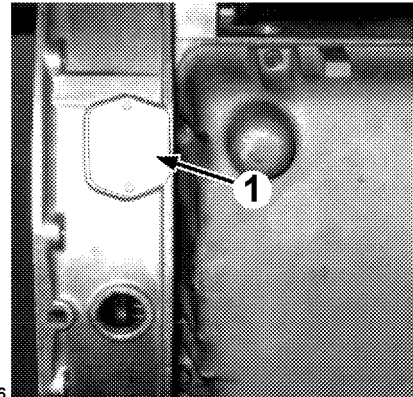

SC119356

Maintenance cover on the flywheel

- Unscrew the maintenance cover **1** from the flywheel housing
- Do not apply too much grease to the ring gear, otherwise the speed sensors will become smeared and subsequently malfunction. Check ring gear and, if necessary, grease lightly with regular lubricating grease
- Screw on the maintenance cover again.

Checking the oil sump and diesel engine bracket for secure seating

It must be ensured that:

- the diesel engine is in the maintenance position

- Check oil sump for secure seating, if necessary tighten the screws.
- Check diesel engine brackets for sound condition and secure seating, if necessary retighten screws.

Checking the induction and exhaust system for sound condition and for leaks

It must be ensured that:

- the diesel engine is in the maintenance position

- Check suction lines between air filter and diesel engine for sound condition, leaks and secure seating.
- Check exhaust lines for sound condition, leaks and secure seating.

5.3.12 Flame-type kit

Checking the flame-type kit

The flame-type kit is arranged on the left-hand side of the diesel engine.

Ensure that the following are on-hand:

- a collecting vessel for the fuel

To check the flame-type start system above 20°C, the temperature cut-off can be deactivated, whereby the pin terminals are withdrawn from the temperature sensors. With the temperature sensor disconnected, the system can be checked when the engine is warm.

Should any malfunctions occur in the system, the electrical function should be checked first.

Danger

Risk of fire and explosion!

! No smoking.

! Avoid naked flames.

- Position a collecting vessel beneath the diesel engine.

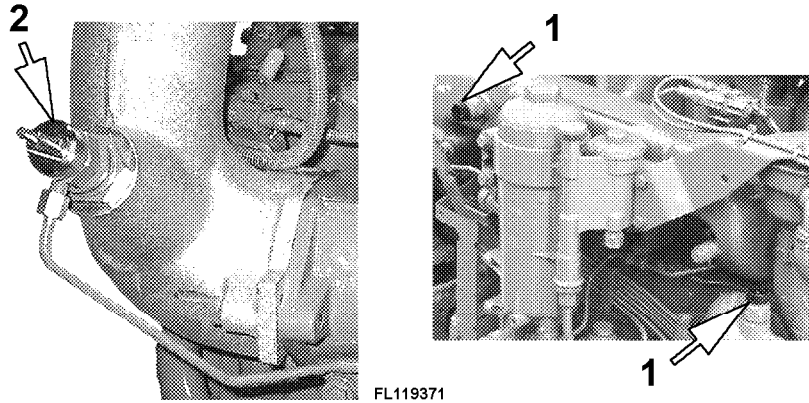
Check functioning of the flame:*Temperature sensors*

- Remove the cable at the temperature sensors 1 .
- Observe the flame glow plug 2 directly through the induction pipe with the system switched on and with the diesel engine running at low speed.

The flame must be clearly formed and be burning fiercely with the engine running at low speed, or, if it is not possible to view the flame directly, the induction pipe must be perceptibly warm in the immediate vicinity of the glow plug.

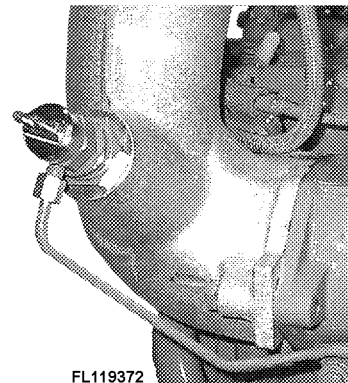
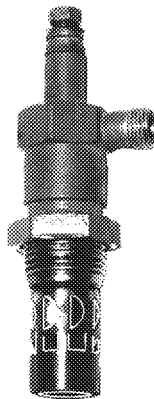
*Checking the glow function*

- Remove the cable at the temperature sensor.
- Remove the flame glow plug and connect the electrical line.
- Manoeuvre the travel starter switch into the travel position so that the indicator lamp lights up (for this procedure, see the User Documentation).

The flame glow plug glows red on the coiled filament when the preheating procedure is complete (50 to 65 sec.).

Troubleshooting

If the coiled filament on the flame glow plug does not glow !

- Replace flame glow plug or check flame start-automatic-relay and replace as required.

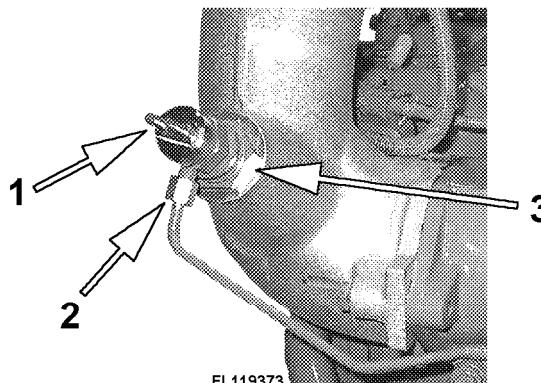
Removing the flame glow plug:*Removing the flame glow plug — Installing the flame glow plug*

- Shut off the electrical line **1** and the fuel line **2** .
- Loosen the lock nut **3** and unscrew the flame glow plug from the induction pipe.

Installing the flame glow plug:

- Apply a coating of sealing compound, Hylomar SQ 32 M, Omnivisic 1050 or Reinzoplast to the thread of the flame glow plug and screw into the induction pipe.
- Align the flame glow plug to the fuel line.
- Connect and tighten the fuel line **2** .
- Tighten the lock nut **3** on the flame glow plug and connect the electrical line **1** .

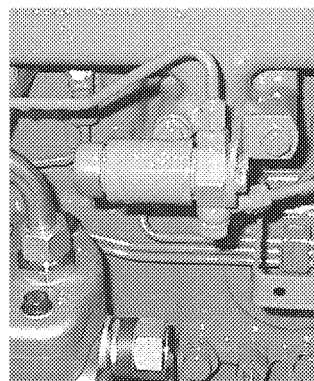
Check the glow function:**Checking the solenoid valve:***Solenoid valve*

- Unscrew the fuel line from the flame glow plug.

- Start the diesel engine.

Fuel flows from the fuel line

- When the diesel engine is running warm, the flow of fuel to the fuel lines stops.

Troubleshooting

If no fuel is being supplied, or if the flow of fuel does not stop when the diesel engine is running!

- Replace the solenoid valve, observing the throughflow direction indicated via the arrow and use new seals.

5.3.13 Fuel pre-filter

Preparing for the cleaning / replacement of the fuel pre-filter filter element

Arrangement of the fuel pre-filter is located on the left-hand side of the diesel engine. Arrangement of the fuel pre-filter with water separator is located at a sufficient distance from the diesel engine.

Ensure that the following are on-hand:

- an original Liebherr filter element

Danger



Risk of fire and explosion!

! No smoking.

! Avoid naked flames.

! Only work on the diesel engine while the diesel engine is switched off.

- If a fuel shut-off valve is available:
Close the fuel shut-off valve.

- Clean fuel pre-filter and surrounding area thoroughly.

Cleaning / replacing the fuel pre-filter filter element

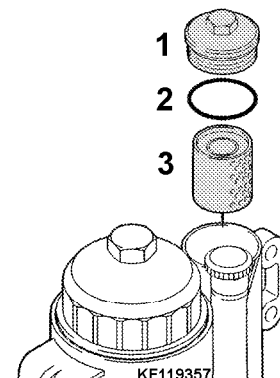
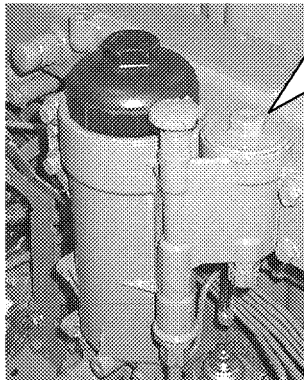

Cleaning / replacing the fuel pre-filter filter element

- Unscrew the housing cover **1** with ring spanner, socket or special tool.
- Remove cover and filter element **3** and clean or replace.
- Replace the sealing ring **2**
- Screw in filter insert and cover and tighten (tightening torque 25 Nm).
- Open the fuel shut-off valve and bleed the fuel system.

Cleaning / replacing the fuel pre-filter with water separator filter element

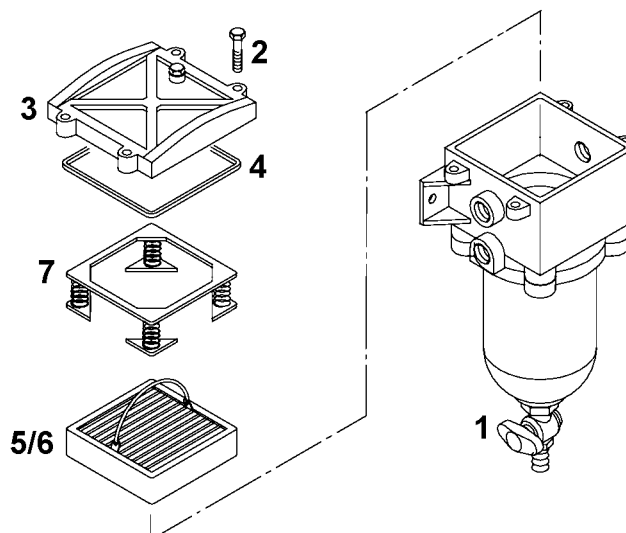

WA118617

Fuel pre-filter

- Push in the drain tap handle **1** and turn in an anticlockwise direction, drain the fuel.
- Unscrew the screws **2** and remove the cover **3** with seal **4** .
- Remove the paper filter element **5** or filter insert **6** together with the spring cartridge **7**
- Dispose of the paper filter element **5** or clean or replace the filter insert **6** .
- Reinstall new paper filter insert **5** or cleaned filter insert **6** .
- Check seal **4**, replace if necessary and reassemble in reverse order.
- Open the fuel shut-off valve and bleed the fuel pre-filter.

5.3.14 Fuel fine filter

Preparing for replacement of the fuel fine filter

Arrangement of the fuel fine filter is located on the left-hand side of the diesel engine..

Ensure that the following are on-hand:

- an original Liebherr filter element

Danger



Risk of fire and explosion!

- ! No smoking.
- ! Avoid naked flames.
- ! Only work on the diesel engine while the diesel engine is switched off.

- If a fuel shut-off valve is available:
Close the fuel shut-off valve.
- Clean fuel fine-filter and surrounding area thoroughly.

Replacing the fuel fine filter element

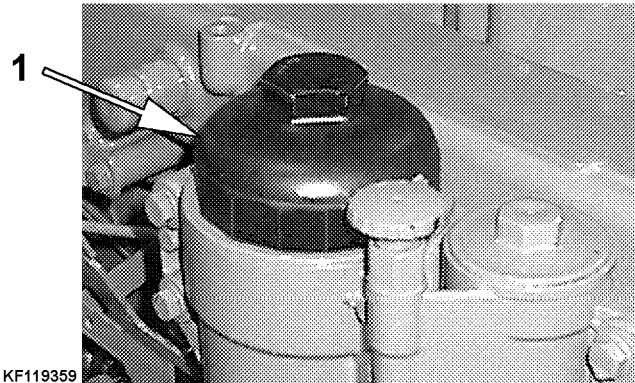

KF119359

Replacing the fuel fine filter element

- Unscrew the housing cover **1** using a ring spanner.
- Wait approx. 2–3 minutes until the fuel runs back into the filter housing.
- Remove the cover and filter element.

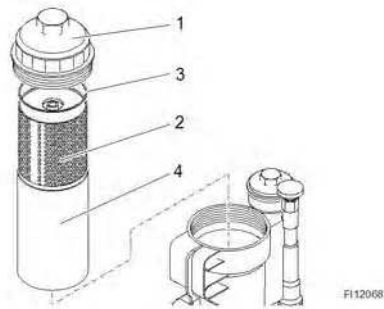

- Remove the filter element **2** from the cover **1**.
- Dispose of the old filter element.
- Remove the sealing ring **3**
- Remove the dirt collector **4** and dispose of the condensed water and contamination in a proper manner
- Clean the dirt collector **4** and reinsert
- Replace the sealing ring **3** and clean the cover if necessary.

Warning



Dirt can cause ruination of the Common Rail System !

! Do not allow any dirt to enter into the clean side of the filter.

! Do not reuse used filter elements.

- Insert a new original Liebherr filter element bearing the “Common Rail” inscription.
- Screw in filter element and cover and tighten (tightening torque 25 Nm).
- Open the fuel shut-off valve.
- Bleed fuel system

5.3.15 Bleed the fuel system

- All tasks on components of the Common Rail System may only be carried out by specially trained personnel.
- Before commencing any work, the diesel engine must be switched off for at least 1 minute in order that any pressure still in the Rail has time to dissipate (pressure pipe).
- Utmost cleanliness must be observed for all tasks in all respective areas (e.g. hands have been washed, clean overalls). Avoid moisture at all costs.

Bleed the fuel system

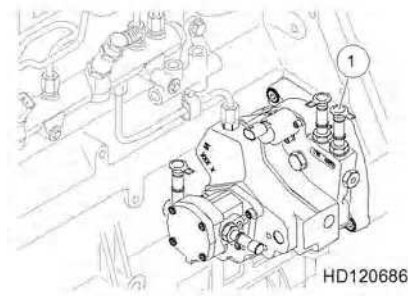

- Open the return-flow line 1 at the high-pressure pump.
- Close the return-flow line 1 using a plug.

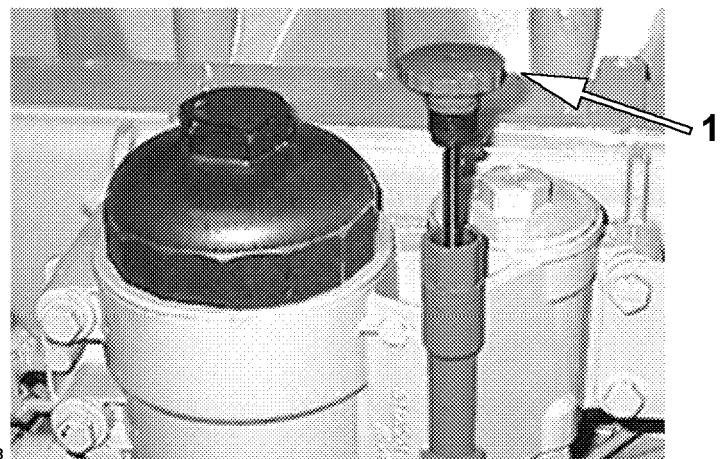

- Unscrew the tappet 1 of the hand pump
- Continue to pump the hand pump until fuel is exuded at the connection of the high-pressure pump for the return-flow line
- Push down the tappet of the hand pump and tighten (tightening torque 4 Nm).
- Remove the plug from the line
- Close the return flow line again
- Check the seals of the Common Rail fuel system

5.3.16 Maintenance tasks every 3200 operating hours

Before carrying out the 3200 operating hours maintenance tasks:

- carry out the daily maintenance tasks, see the section “Maintenance Tasks (daily), every 10 operating hours”.
- carry out the weekly maintenance tasks, see the section “Maintenance Tasks (weekly), every 50 operating hours”.
- carry out the 400 operating hours maintenance tasks, see the section “Maintenance Tasks, every 400 operating hours”.
- carry out the 800 operating hours maintenance tasks, see the section “Maintenance Tasks, every 800 operating hours”.

5.3.17 Cooling system

Replacing the coolant

It must be ensured that:

- the diesel engine is in the maintenance position
- the diesel engine has cooled
- the heating taps, if featured, are open
- a collecting vessel and coolant, see “Fuel and Lubricants”, for filling amounts see “manufacturer's documentation”, are on-hand.

Draining the coolant

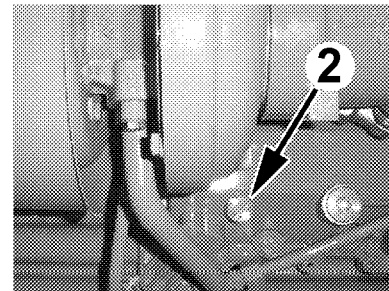
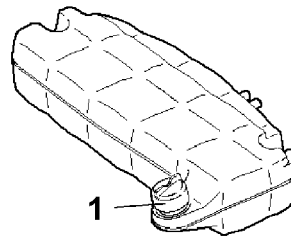

KUE119369

Draining the coolant

- Avoid opening the sealing cap 1 when the diesel engine is too warm.
- Turn the sealing cap very slightly anticlockwise until the excess pressure is dissipated, then open.
- Position the container under the diesel engine
- Open the drain plug at the lowest point of the coolant circuit or on the cooler (see manufacturer's documentation).

The coolant from the cooling system flows into the container.

To drain the coolant completely from the diesel engine, the following step is to be carried out wherever necessary.

- Unscrew the drain plug 2 on the heat exchanger on the right-hand side of the diesel engine.
- When the coolant has been drained from the cooling system or the heat exchanger.

Screw in the drain plug once again and tighten.

Filling in coolant.

- Only fill in prepared coolant with 50 vol.– % anticorrosive/antifreeze at the expansion tank
- Fill cooling system to maximum level.
- Fit and lock the sealing cap on the expansion tank.
- Start the diesel engine and allow to run warm.
- Check the coolant level again and top up as required.

Ensure that the coolant contains at least 50 vol.– % anticorrosive / antifreeze.

5.3.18 Maintenance tasks as required

It must be ensured that:

- the diesel engine is in the maintenance position
- a collecting vessel has been prepared
- the respective maintenance material is on-hand

5.3.19 Diesel engine

Replacing the oil separator

It must be ensured that:

- the diesel engine is in the maintenance position
- an oil separator with new O-ring is on-hand

Removing the oil separator:

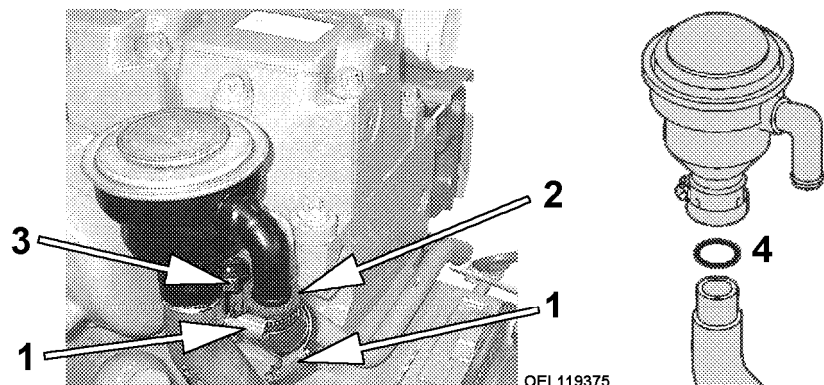

Removing — Installing

- Loosen the hose clamps 1 and push the hose 2 from the oil separator.
- Loosen the fastening clamps 3 and remove the oil separator.

Installing the oil separator:

- Insert a new O-ring 4 at the support.
- Slide the oil separator onto the supports and tighten the fastening clamp.
- Mount the brackets, slide on the hose and tighten the hose clamps.

5.3.20 Dry-air filter

Replacing the dry air filter main element

The dry air filters vary depending on the design of the machine .

If an air filter contamination continues to be displayed following maintenance of the main element, the safety element must also be replaced.

- For replacement of the main element, see the “manufacturer's documentation”.

Replacing the dry air filter safety element

The safety element only needs replacing with every third replacement of the main element, **however, at least once a year.**

- For replacement of the safety element, see “manufacturer's documentation”.

5.3.21 Cooling system

Degreasing the cooling system

It may be necessary to degrease the cooling system if leaks at the:

- cylinder head gaskets,
- oil cooler seals,
- oil cooler and oil cooler grill

causes diesel engine oil to run into the cooling water circuit.

Following rectification of any damage, the cooling system must be degreased before coolant is filled in.

It must be ensured that:

- the diesel engine is in the maintenance position,
- the maintenance task “draining the coolant” has been carried out.
- a degreasing agent: 5%-diluted solution of P3 Standard or P3T 5124, supplier: Henkel company is on-hand and the manufacturer's instructions are adhered to.
- a seal for the thermostat housing is on-hand.
- a collecting vessel and coolant, mix ratio see “Fuel and Lubricants”, for filling amounts see “manufacturer's documentation”, are on-hand.
- Remove both coolant thermostats, lock in an open position and reinstall
- Fill cooling system completely with a mixture of water and 5% degreasing agent.
- Run the diesel engine with heating switched on until a coolant temperature of 90° C has been attained.
- Allow the diesel engine to run for approx. 5 minutes at this temperature.
- Switch off diesel engine and allow cooling system to cool to approx. 50° C.

When the cooling system has cooled to approx. 50° C.

Caution

Danger of scalding as a result of degreasing agent being squirted out!

! Only open the sealing cap on the expansion tank when the diesel engine has cooled - the coolant temperature display on the segment field of the display unit should be in the lower third of the segment field.

- Drain degreasing agent.
- Fill cooling system with fresh water.
- Allow the diesel engine to run for approx. 5 minutes for scavenging.
- Drain scavenging water, fill cooling system once again with fresh water and repeat the scavenging procedure.
- Remove coolant thermostats, readjust them back to the normal position and install with new thermostat housing.
- Carry out the maintenance task "fill in coolant"..

Decalcifying and derusting the cooling system

Decalcifying and derusting of the cooling system is necessary if coolant has been filled:

- which is not permissible,
- or has too low a mix ratio.

Impermissible coolant can lead to sedimentation or corrosion in the cooling system.

Sedimentation can cause leaks in the coolant pumps or deficient cooling capacity due to the interior of the cooler becoming clogged.

It must be ensured that:

- the diesel engine is in the maintenance position,
- the maintenance task "draining the coolant" has been carried out.
- a decalcifying or derusting agent: 10%-diluted solution of citric acid, tartaric acid or oxalic acid, obtainable from chemical dealers, is on-hand.
- a seal for the thermostat housing is on-hand.
- a collecting vessel and coolant, mix ratio see "Fuel and Lubricants", for filling amounts see "manufacturer's documentation", are on-hand.
- Remove both coolant thermostats, lock in an open position and reinstall
- Fill cooling system completely with a mix of water 10% decalcifying or derusting agent.
- Run the diesel engine with heating switched on until a coolant temperature of 90° C has been attained.
- Allow the diesel engine to run for approx. 10 minutes at this temperature.
- Switch off diesel engine and allow cooling system to cool to approx. 50° C.

When the cooling system has cooled to approx. 50° C.



Danger of scalding as a result of decalcifying or derusting agent squirting out!

! Only open the sealing cap on the expansion tank when the diesel engine has cooled - the coolant temperature display on the segment field of the display unit should be in the lower third of the segment field.

- Drain decalcifying or derusting agent .
- Fill cooling system with fresh water.
- Allow the diesel engine to run for approx. 5 minutes for scavenging.
- Drain scavenging water, fill cooling system once again with fresh water and repeat the scavenging procedure 3 to 5 times.
- Remove coolant thermostats, readjust them back to the normal position and install with new thermostat housing.
- Carry out the maintenance task "fill in coolant"..

5.3.22 Transport

Lifting device

It must be ensured that:

- a suitable lifting device is on-hand.

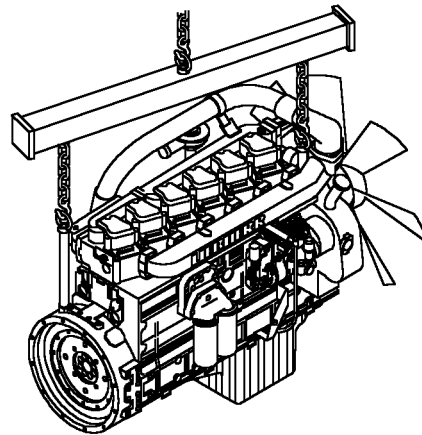

Lifting device

- A proper lifting device must be used when moving the diesel engine. Hang the diesel engine on the lifting lugs provided.

5.3.23 Storage

Storage up to 6 months

The LIEBHERR diesel engine has been preserved from the date on which it was declared ready for shipment, with normal storage in a dry, well-ventilated area, the preservation protection period is 6 months.

If in addition, the diesel engine is covered with plastic sheeting, it may also be left out in the open for up to a month.

The cover must be watertight and be wrapped loosely around the diesel engine in order that the air can circulate around the diesel engine, thus preventing any condensation forming.

Should the specified measures be deviated from, whereby the preserved diesel engine is submitted to less favourable conditions (longer periods of storage in the open air or storage in damp, unventilated places etc.), a curtailment of the preservation protection period must be considered.

Storage for longer than 6 to 24 months

When storing for longer than 6 to 24 months, a full-scale preservation must be undertaken, consult LIEBHERR Service or a LIEBHERR authorised dealer.

Removing the preservation after 6 months of storage

- Remove all fitted connections.

Exterior preservation is to be removed with degreasing solvent, white spirit or petroleum wherever necessary (e.g. with a leak test).

If high-pressure cleaning equipment is used, white spirit is recommended as a solvent.

Intensive spraying of electrical parts, plug connections and rubber or plastic parts, as well as water temperatures exceeding 80 °C should be avoided to prevent irreversible damage

- Following installation and connection of the diesel engine
Permissible fuels should be kept topped up to maximum levels, see "Fuel and Lubricants".

5.3.24 Confirmation of maintenance tasks which have been carried out

Maintenance details

Diesel engine - type:
Diesel engine - no.:
Start-up on:
Customer:
Location:
Street:
Liebherr - subsidiary:
Location:
Street:
Telephone/Fax:

Note:

Operation and maintenance are decisive as to whether a diesel engine is ready for operation at all times and remains in fully-working order.

We strongly recommend that the prescribed maintenance tasks are performed thoroughly and punctually. Warranty claims only remain valid if this point is strictly adhered to. Seals on the injection pump and on the governor are not to be broken !

The correct carrying out of maintenance tasks must be entered and confirmed in the following maintenance chart.

The maintenance tasks for daily and 50 operating hours maintenance intervals must be performed by service personnel authorised by the customer.

The first oil-change and replacement of the oil filter, as well as all further maintenance tasks, must be carried out by a LIEBHERR-trained, authorised mechanic.

5.3.25 every 400 operating hours / at least once a year

- With more difficult operating conditions
 - repeated cold-starts,
 - fuel sulphur content above 0.5 %,
 - application temperature below -10 °C
 - poor oil quality,

the prescribed oil-change intervals must be halved, see "Fuel and Lubricants".

Hours	Date	Mechanic	Signature	Remark
400				
800				

LMB/01/003801/16.5/en/Version::06.06.2005

Hours	Date	Mechanic	Signature	Remark
1200				
1600				
2000				
2800				
3200				
3600				
4000				
4400				
4800				
5200				
5600				
6000				
6400				
6800				
7200				
7600				
8000				
8400				
8800				
9200				
9600				
10000				
10400				
10800				
11200				
11600				
12000				
12400				
12800				
13200				
13600				
14000				
14400				
14800				
15200				
15600				
16000				
16400				

5.3.26 Additionally, every 800 / 1600 / 2400 / 3200 operating hours

Hours	Date	Mechanic	Signature	Remark
800				
1600				
2400				
3200				
4000				
4800				
5600				
6400				
7200				
8000				
8800				
9600				

LMB/01/003801/6.5/en/Version:: 06.06.2005

Maintenance tasks

Hours	Date	Mechanic	Signature	Remark
10400				
11200				
12000				
12800				
13600				
14400				
15200				
16000				

5.3.27 Additionally every 2 years

Hours	Date	Mechanic	Signature	Remark
2 years				
4 years				
6 years				
8 years				
10 years				
12 years				
14 years				
16 years				
18 years				
20 years				

5.4 Lubricants and fuels

5.4.1 Handling lubricants and fuels

Conscientious adherence of the guidelines for handling fuel and lubricants increases reliability and life-expectancy of the diesel engine.

It is of particular importance that the prescribed lubricant qualities are adhered to.

Miscellaneous details regarding the prescribed intervals can be obtained in the chapter, "Maintenance and Inspection Chart".

Miscellaneous details for carrying out: lubrication, checking levels and changing fuel can be obtained in the chapter, "Maintenance" under "Maintenance Tasks".

All handling of fuel and lubricants must be undertaken as follows and the environmental-protection guidelines must be observed.

5.4.2 Environmental-protection measures

- The environmental-protection guidelines must be observed at all times.
- Note the guidelines which apply for the respective country.
- Ensure the correct disposal of any fluids before draining.

5.4.3 Disposing of recyclables

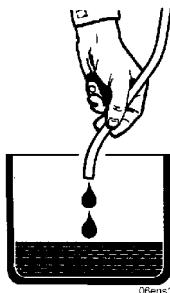

Disposal

Recyclables include for example:

- Oils, lubricants, coolant, refrigerating agents for air-conditioning systems etc.
- Fuels
- Filters, oil filter cartridges etc.
- Observe the guidelines for environmental-protection when disposing of recyclables.
- Collect all recyclables separately in suitable containers, store in a safe place and dispose of in an environmentally-friendly manner at an official site.
- Note the guidelines which apply for the respective country.

5.4.4 Lubricant and fuel specifications

Adhering to the guidelines for fuel and lubricants increases reliability and life-expectancy of the diesel engine.

It is of particular importance that the prescribed specifications are adhered to.

5.4.5 Diesel fuels

Specification



06sy02ab

The diesel fuels must comply with the minimum requirements of the fuel specifications prescribed as follows.

Authorised fuel specifications:

- DIN EN 590
- ASTM D 975 (89a) 1D and 2D

Further fuel specifications only upon consultation with the Diesel Engine Development Department, LIEBHERR Machines Bulle S.A.

Sulphur content in the diesel fuel

In DIN EN 590, a max. 350 mg/kg = max. 0.035 weight.% sulphur content is permissible.

“Low-sulphur” diesel fuels featuring a sulphur content of below / less than 0.05 weight% are only applicable if lubricity can be guaranteed with the admixture of additives. The diesel fuel lubricating proficiency must be a max.460 µm in accordance with the HFRR (60) test. [lubricity corrected “wear scar diameter” (1.4) at 60°C]

For diesel fuels featuring a sulphur content above / more than 0.5 weight.%, the oil-change intervals are to be halved.

Diesel fuels featuring a sulphur content above / more than 1 weight% are not permissible.



Note:

Authorisation can be granted in accordance with the diesel engine lube-oil quality !

Fuel standard ASTM D 975 does not stipulate that the fuels must pass a fuel-lubricity test. A written confirmation of the fuel supplier must be requested. Any additions should be undertaken by the supplier as he is responsible for the quality of the fuel. The addition of secondary-lubricity-additives by the customer is not recommended.

- **A cetane number of at least 45** is required for fuels in accordance with ASTM D975. A cetane number above 50 is preferable, especially with temperatures below 0°C or 32°F.

Diesel fuel at low temperatures (winter operation)

Paraffin crystals in the diesel fuel become separated as ambient temperatures drop, increasing flow resistance in the fuel filter to such an extent that a sufficient supply of fuel to the diesel engine can no longer be guaranteed.

In moderate climates, a cold-flow property of up to:

0°C from 15.04. 30.09.

-10°C from 01.10. - 15.11./1.3. 14.04.

-20°C from 16.11. 29.02.

is guaranteed in accordance with DIN EN 590.

5.4.6 Coolant for diesel engines

General recommendations

The cooling system will only function reliably if it is working under initial pressure. It is therefore imperative that it is kept clean and watertight, that the radiator cap valve and working valves are functioning correctly and the necessary coolant level is maintained.

The anticorrosive/antifreeze authorised by us guarantees sufficient protection against cold, corrosion and cavitation, do not corrode seals and hoses and do not foam up.

The cooling system of the engines should be filled all year round with a mixture of 50% water and 50% anticorrosive/antifreeze, guaranteeing protection against cold down to a temperature of -37°.

Coolant Coolants which contain inadequate, or ill-prepared or incorrect anticorrosive/antifreeze, could cause a malfunctioning of aggregates or parts in the cooling circuit as a result of cavitational or corrosive damage. Additionally, heat-insulating sedimentation can form at heat transferring parts, causing an overheating, and ultimately malfunctioning of the engine. For a continuous, fault-free operation of Liebherr diesel engines, the coolant must comprise of 50% water and 50% anticorrosive/antifreeze. In special cases, it is permissible to use anticorrosives (inhibitors). Emulsifiable corrosion inhibition oils are strictly impermissible.

Mix chart / mix ratio water:
anticorrosive/antifreeze

	°C	°F	Water %	Anticorrosive/antifreeze %
Ambient temperature	-37	-34	50	50
Ambient temperature	-50	-58	40	60

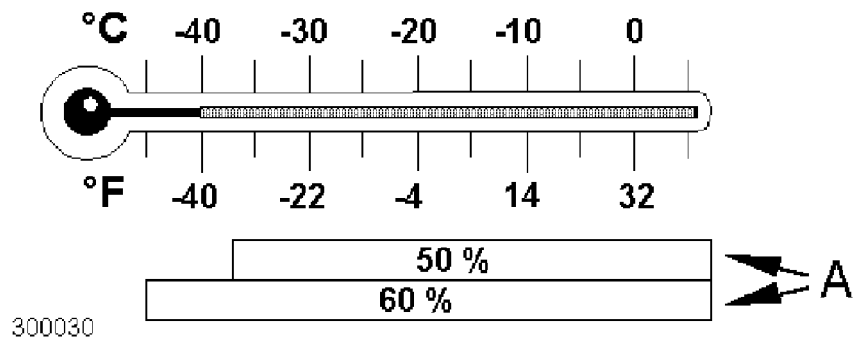

Temperature-dependent selection of the mix ratio of anticorrosive and antifreeze

A = percentage % of the antifreeze

Checking and renewing the coolant

- Always top up any losses of coolant with a mixture of water and a min. 50 vol.% anticorrosive/antifreeze.
- Never allow the anticorrosive/antifreeze concentration to fall below 50 vol.%.
- Never use more than 60% anticorrosive/antifreeze, as the cooling effect and the frost protection is reduced with too high a percentage.

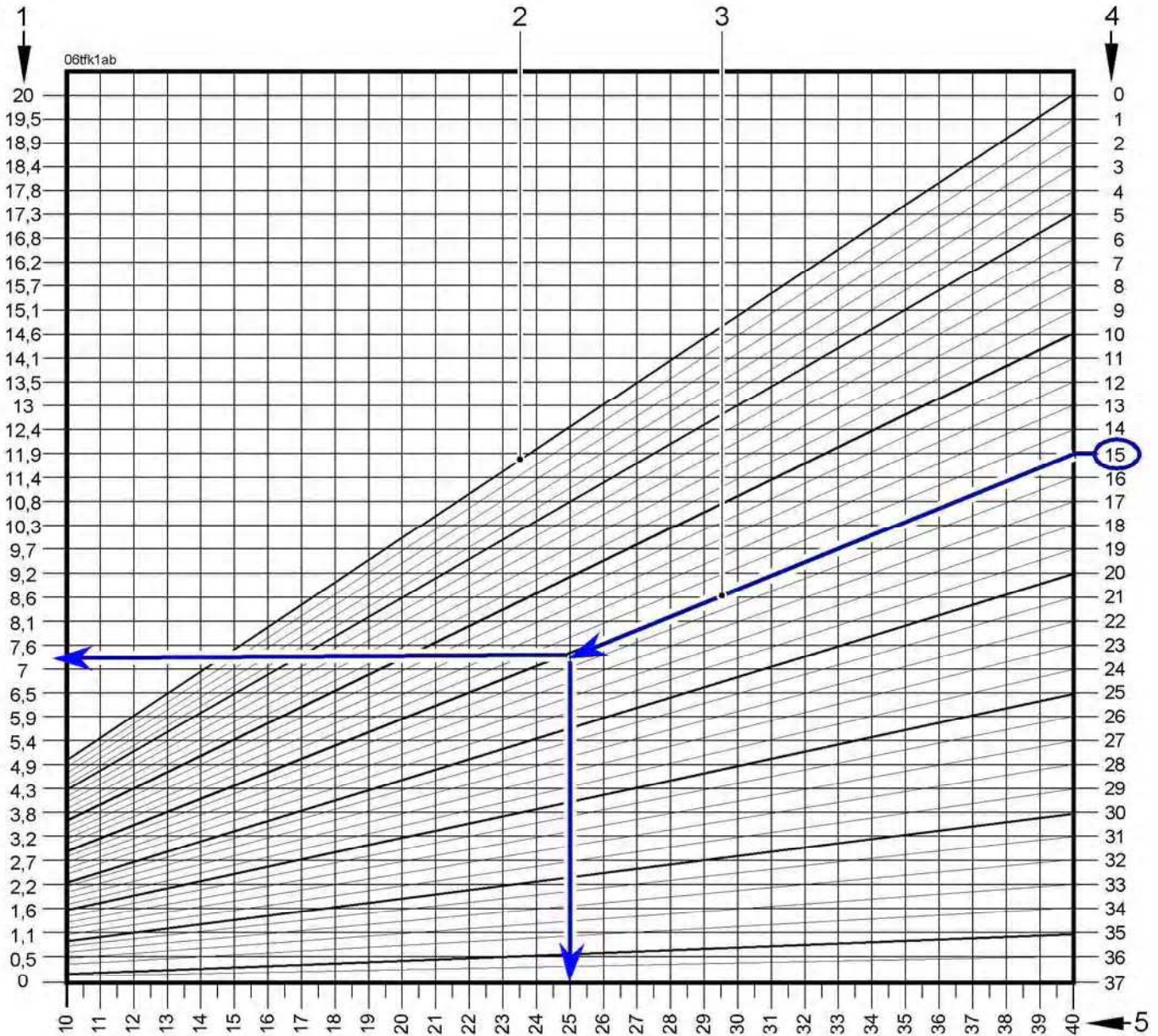

Selection of antifreeze concentration

LMB/01/003801/6.5/en/Version::06.06.2005

- Procedure for example -15 °C: if a temperature of -15 °C has been measured in the cooling system, follow guide line 3 (starting at the measured temperature) down to the left until reaching the vertical line filling amount - cooling system 5, and then from this point out to the left horizontally.

This will show how much pure anticorrosive/antifreeze 1 must be topped up to once again attain -37° C freeze protection.

- To ensure that the correct mix ratio is achieved once again, at least the amount previously determined must be drained from the cooling system.
- Fill in the determined amount of pure anticorrosive/antifreeze.
- To attain the required coolant level, refill the remainder with the previously drained coolant.

Water (fresh water)

Suitable water is colourless, clear, free of mechanical contamination, drinkable tap water featuring the following restricted analysis values.

Sea water, brackish water, salt water and industrial waste water is not suitable.

Model	Value and unit
Total of alkaline earths (water hardness)	0.6 to 3.6 mmol/dm ³ (3 to 20° d)
pH-value at 20 °C	6.5 to 8.5
Chloride-ion content	max. 80 mg/dm ³
Sulphate-ion content	max. 100 mg/dm ³

Fresh water quality when using anticorrosive/antifreeze

Model	Value and unit
Total of alkaline earths (water hardness)	0.6 to 2.7 mmol/dm ³ (3 to 15° d)
pH-value at 20 °C	6.5 to 8.0
Chloride-ion content	max. 80 mg/dm ³
Sulphate-ion content	max. 80 mg/dm ³

Fresh water quality when using anticorrosive DCA 4

Drinking water analyses can be applied for from the communal authorities responsible.

Anticorrosives (inhibitors)

In **exceptional cases** and **if ambient temperatures constantly remain above freezing point**, e.g. in tropical regions where **there is apparently no authorised anticorrosive/antifreeze available**, the following may be used as coolant.

Product DCA 4 (Diesel Coolant Additives 4) **without antifreeze**

When carrying out maintenance tasks, the DCA 4-concentration must be tested and rectified as necessary.

Test-Kit CC 2602 M from Fleetguard is recommended for testing.

The DCA 4 concentration must be between 0.6 and 1.06 units per litre.

Product Caltex / Chevron Texaco / Havoline / Total without antifreeze

When carrying out maintenance tasks, the mix ratio must be checked when using Caltex / Chevron Texaco / Havoline / Total and rectified as necessary.

The refractometer 2710 from the Gefo company is recommended for testing.

The correct mix ratio must be 7.5 % anticorrosive and 92.5 % water.

Checking the mix ratio using a refractometer



RE120464

Geko refractometer no. 2710

Refractometer

- Adjusting screw for setting the 0–line (water line)
- The visual acuity is adjusted by turning the ocular.
- Soft eye-piece on the ocular.
- Dimensionally-stable metal housing
- Non-slip grip made of rubber armouring

Measuring procedure

- Clean cap and prism carefully
- Apply 1–2 drops of test fluid to the prism.
- The test fluid is distributed by closing the flap.
- Look through the ocular at a bright background and focus the scale.
- Read the values on the blue separation line.

Conversion chart

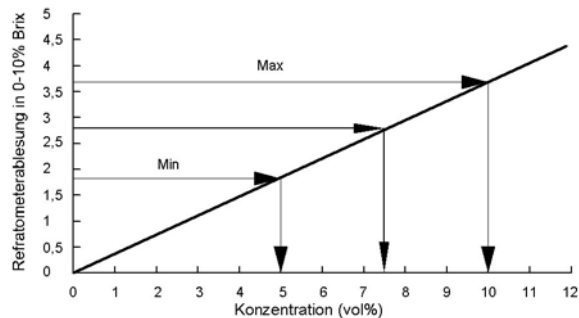

Concentration measured with a Brix refractometer for

- Chevron Texaco Heavy Duty Extended Life Corrosion Inhibitor Nitrite Free / Chevron Texaco
- Havoline Extended Life Corrosion Inhibitor (XLI) / ARTECO
- Caltex CL Corrosion Inhibitor Concentrate / Caltex
- Total WT Supra / Total

**Permissible anticorrosives
(inhibitors) for diesel engine
cooling systems**

	Product designation	MANUFACTURER
D	DCA 4 Diesel Coolant Additives	Fleetguard
C	Caltex CL Corrosion Inhibitor Concentrate	Caltex
	Chevron Texaco Heavy Duty Extended Life Corrosion Inhibitor Nitrite Free	Chevron Texaco
H	Havoline Extended Life Corrosion Inhibitor (XLI)	ARTECO
T	Total WT Supra	Total

The coolant must be changed once a year.

The coolant is to be drained completely when changing from anticorrosive/antifreeze to anticorrosive or vice versa.

**Disposing of
anticorrosive/antifreeze**

Undiluted anticorrosive/antifreeze should be treated as hazardous waste. When disposing of used refrigerants (mixture with water) the guidelines of the local authorities responsible are to be observed.

**Permissible anticorrosive /
antifreeze (concentrates) for
diesel engine cooling systems**

	Product designation	MANUFACTURER
A	Agip Antifreeze Plus	Agip Petroli S-P.A. / ROM
	Agip Langzeit-Frostschutz	Autol-Werke GmbH, Würzburg
	Antigel DB 486	Sotragal SA, St-Priest/France
	Aral Kühler-Frostschutz A	Aral AG, Bochum
	AVIA Frostschutz APN (G48-00)	Deutsche AVIA-Mineral-Oel-Ges.mbH Munich
B	BP anti frost X 2270 A	Deutsche BP AG, Hamburg
	BP Nappgel C 2270/1	BP Chemicals Ltd., London/England
C	Caltex Engine Coolant DB	Caltex (UK) Ltd., London/England
	Caltex Extended Life Coolant	Caltex
	Castrol Anti-Freeze O	Deutsche Castrol Vertriebsges.mbH,Hamburg
	Century F.L. Antifreeze	Century Oils, Hanley, Stoke-on-Trent/England
	Chevron DEX-COOL Extended Life Anti-Freeze/Coolant	Chevron Texaco
D	DEUTZ Kühlschutzmittel 0101 1490	DEUTZ Service Intl. GmbH (DSI), Cologne
E	Esso Kühlerfrostschutz	Esso AG, Hamburg
F	Fricofin	Fuchs Mineralölwerke GmbH, Mannheim
	Frostschutz Motorex (G 48-00)	Bucher + Cie, Langenthal/Switzerland
	Frostschutz 500	Mobil Oil AG, Hamburg
G	Glacelf Auto Supra	Total
	Glycoshell AF 405	Shell
	Glycoshell N	Shell
	Glysantin (G48-00)	BASF AG, Ludwigshafen
H	Havoline XLC	ARTECO
	Havoline DEX-COOL Extended Life Anti-Freeze/Coolant	Chevron Texaco
I	Igol Antigel Type DB	Igol France, Paris/France

	Product designation	MANUFACTURER
L	Labo FP 100	Labo Industrie, Nanterre/France
M	Motul Anti-Freeze	Motul SA, Aubervilliers Cedex/France
O	OMV-Frostschutzmittel	OMV AG, Schwechat/Austria
	Organifreeze	Total
	OZO Frostschutz S	Total Deutschland GmbH, Düsseldorf
T	Total Antigel S-MB 486	Total Deutschland GmbH, Düsseldorf
	Total Frostfrei	Total Deutschland GmbH, Düsseldorf
V	Veedol Antifreeze O	Deutsche Veedol GmbH, Ham- burg
W	Wintershall Kühlerschutz	Wintershall Mineralöl GmbH, Düsseldorf

LIEBHERR

**anticorrosive/antifreeze / 50:50
premix for diesel engine cooling
systems**

Permissible

**anticorrosive/antifreeze / 50:50
Premix for diesel engine cooling
systems**

LIEBHERR Anti-Freeze APN Mix

Ident. no. 8611045 – 20 litre drums

	Product designation	MANUFACTURER
C	Caltex Extended Life Coolant Pre-Mixed 50/50 (ready-to-use- version)	Caltex
	Chevron DEX-COOL Extended Life Prediluted 50/50 Antifreeze coolant	Chevron Texaco
H	Havoline XLC, 50/50	ARTECO
	Havoline DEX-COOL Extended Life Prediluted 50/50 Antifreeze coolant	Chevron Texaco
O	Organicool 50/50	Total

5.4.7 Lube-oils for the diesel engine**Lube-oil quality**

06sy05ab

Only high-alloy lube-oils are used nowadays for modern diesel engines. They are comprised of base oils which feature combined admixtures (additives).

The lube-oil guidelines for LIEBHERR diesel engines are based on the following specifications and guidelines:

Model	Specification
ACEA — Classification (Association des Constructeurs Européens de l'Automobile)	E4, E5
API — Classification (American Petroleum Institute)	Observe the CI-4, CH-4 special oil-change intervals

Lube-oil viscosity

Selection of the lube-oil viscosity in accordance with the SAE-classification (Society of Automotive Engineers).

The ambient temperature is definitive for the correct selection of the SAE-class.

Selection of the SAE-classification gives no indication of the quality of a lube-oil.

Too high a viscosity can lead to starting difficulties, and too low a viscosity could jeopardise the lubricating efficiency.

The temperature ranges specified in the diagram are guidelines and can be briefly exceeded or fallen short of.

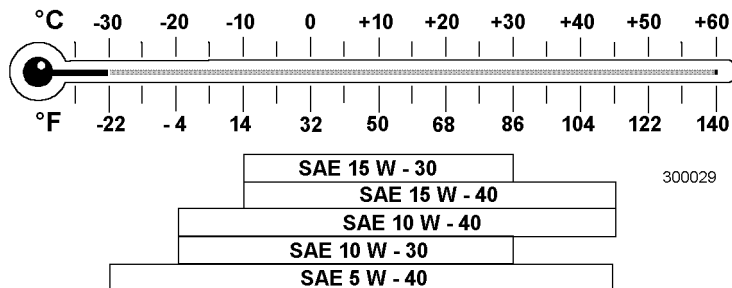

Temperature-dependent selection of the SAE-class

The following diesel engine oil is recommended (for ambient temperatures of -20°C / 4°F to +45°C / 113°F):

LIEBHERR diesel engine oil

- SAE 10W-40 / specification ACEA E4
- Ident. no. 8610049 – 20 litre drums

Lube-oil change intervals

Change intervals

- First oil and filter change upon utilisation of initial filling oil: see chapter “Maintenance and Inspection Chart”
- Oil-change respective of climatic zone, sulphur content in the fuel and oil quality in accordance with the following table

If the prescribed operating hours (Bh) have not expired within one year, the diesel engine oil and filter must be replaced at least once a year.

LMB/01/003801/6.5/en/Version::06.06.2005

Difficulty factors Various difficulty factors or more difficult operating conditions reduce maintenance intervals.

Difficulty factors or difficult operating conditions include for example:

- frequent cold-starts
- sulphur content in the fuel over 0.5%
- application temperature below -10 °C

When working with difficulty factors or in tougher operating conditions, the oil-change intervals prescribed in the “Maintenance and Inspection Chart” must be carried out in accordance with the following chart.

Difficulty factor		Oil quality	
		CI-4	
		CH-4	
			E4
			E5
Operating conditions	Sulphur content in the fuel	Interval	
Temperature normal down to -10 °C	up to 0.5%	200 Bh	400 Bh
	over 0.5%	100 Bh	200 Bh
below -10 °C	up to 0.5%	100 Bh	200 Bh
	over 0.5%		100 Bh

Oil-change intervals in operating hours (Bh)

Liebherr-Hydraulikbagger GmbH

Hans-Liebherr-Straße 12
D-88457 Kirchdorf/Iller
☎ + 49 7354 80-0
Fax + 49 7354 80-72 94
www.liebherr.com
E-Mail: info@lhb.liebherr.com

Liebherr-France SAS

2, Avenue Joseph Rey, B.P. 287
F-68005 Colmar Cedex
☎ + 33 389 21 30 30
Fax + 33 389 21 37 93
www.liebherr.com
E-Mail: info@lfr.liebherr.com

Liebherr-Werk Telfs GmbH

Hans-Liebherr-Straße 35
A-6410 Telfs
☎ + 43 5262 6 00-0
Fax + 43 5262 6 00-72
www.liebherr.com
E-Mail: info@lwt.liebherr.com

Liebherr-Werk Bischofshofen GmbH

Postfach 49
A-5500 Bischofshofen
☎ + 43 6462 8 88-0
Fax + 43 6462 8 88-3 85
www.liebherr.com
E-Mail: info@lbh.liebherr.com